

## A Survey on the Investigation and Analysis for a Power System (Micro-Grid) with Stochastic Harmonic Distortion of Multiple Converters

Vaishali P. Kuralkar<sup>1</sup>, Prabodh Khampariya<sup>2</sup>, Shashikant M. Bakre<sup>3</sup>

Submitted: 03/11/2022

Revised: 11/01/2023

Accepted: 01/02/2023

**Abstract:** The current study is based on a survey on the exploration and analysis of stochastic harmonic distortion in power systems using multiple converters (Micro-Grid). When Renewable Energy Systems are integrated into EPS, they may create clean energy, fulfill consumer energy needs, and help to protect fossil fuel supplies, which are rapidly dwindling. These renewable energy sources are frequently interconnected to the grid through power converters (Voltage Source Converters) to provide the necessary energy regulation and conversion. However, Voltage Source Converter (VSCs) generates both current and voltage harmonics, has a negative impact on the Power Quality of a small grid and has potential to cause damage or equipment failure. In the face of uncertainties, such as those resulting from design parameter selection or system parameter changes, the amount of harmonic distortion of many VSCs may be greatly influenced and difficult to forecast. When dealing with VSC harmonic distortion levels in the face of uncertainty, it is necessary to use statistical methodologies.

**Keywords-** Stochastic harmonic distortion, Micro-Grid, Voltage Source Converters, Power Quality, RES.

### 1. Introduction

One of the novel ideas employed in part of today's EPS is the EPS grid, which may be thought of as a tight control of small generators, storage devices, and loads to boost renewable and/or other application generation. This concept is illustrated in Fig.1.1, which shows wind turbines and photovoltaic panels are examples of renewable energy producers a Combined Energy and Energy system for the production of various energy, loads, and energy storage batteries, as well as a Combined Energy and Energy (CHP) system for the production of various energy, loads, and energy storage batteries.

Micro grids have the benefit of being able to provide their location, which may be a small village or an industrial region, with electricity generated by their own tiny distributed generating plants, and they may also be utilized to help the grid meet its load demands. Grid disconnectivity may occur during a malfunction or other network anomaly. When working in isolation mode, also known as island mode, appropriate control and operational strategies, and protection systems maintain a balance between supply as

well as demand and maintain a steady supply of local resources even if the public grid is turned off, the system is said to be equitable .

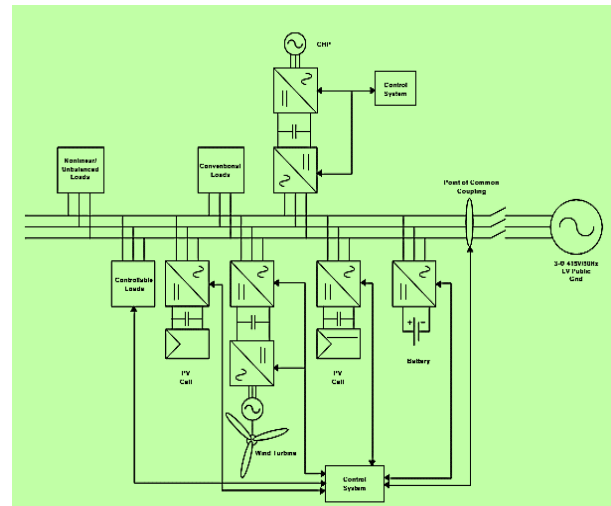

**Fig. 1.1:** Concept of a Micro grid

### 2. Literature Survey

The following are the papers that were chosen for the investigation:

Ahmed, E. M., et al. (2019) [1] proposed a multi-component power supply controller (MPPT) for the integration of the PV systems grid. The suggested MPPT control, which is based on the use of a four-legged multilevel transformer with three T levels, described in detail below. Among the many functions performed by the proposed MPPT inverter

<sup>1</sup>Research Scholar, Department of Electrical Engineering, School of Engineering, SSSUTMS, Sehore, M.P.(India)

<sup>2</sup>Professor, Department of Electrical Engineering, School of Engineering, SSSUTMS, Sehore, M.P.(India)

<sup>3</sup>Associate Professor, Department of Electrical Engineering, AISSMS IOIT, Pune(India)

<sup>1</sup>vaishali.kuralkar@gmail.com,

<sup>2</sup>khampariya5@gmail.com,

<sup>3</sup>shashikant.bakre@aissmsioit.org

are distributed, the current neutral adjustment of unequal loads, providing efficient power to the grid, and grid integration, among others. In addition, the proposed inverter is able to overcome the stochastic behavior of both PV products with a certain shade weight and its performance with uneven loads. In addition, a new proposed controller injects a sinusoidal outlet to a grid with lower levels of complete harmonic distortion (THD) than the previous control. Various operational scenarios for PV production and load demand are studied using the case study that has been thoroughly tested. The findings, as well as the tabulated performance comparisons, have shown that the suggested multifunctional PV generating system outperforms the competition. The results show that the suggested controller is capable of obtaining distributed maximum power point tracker for all photovoltaic modules under all of the investigated conditions. Additionally, the removal of the neutral current caused by imbalanced loads in the system results in an improvement in the overall energy efficiency of system.

Ala, G., et al. (2019) [2] conducted an experimental investigation into how much harmonic content is present in the voltages generated by the three five phase MI (H-Bridge) controlled by Control board based on FPGAs. Attempt was also made to test effectiveness of FPGA using most common methods : variability and comparison simulation as well as test results. For the control algorithms, the VHDL language has been used. The voltage waveforms obtained as output , which were created by applying the major PWM approaches to the inverter, are compared in terms of the THD percent. outcomes of simulation and experimentation are analysed, compared as well as explained .

Al-duaij, E. O. S. (2015) [3] introduced the harmonics in the power system, by explaining the meanings of the harmonic, causes, and sources. Then there are the impacts of harmonics on the electrical power supply. The harmonics were computed and examined by the team. They investigated the impact of harmonics on the electrical power supply. They also demonstrated how to reduce harmonics from the power system in the fourth part of their presentation. Aiming to understand and search for the sources and consequences of harmonics in the public electric supply system, they conducted a library search and conducted experiments to accomplish their goal. The results of their inquiry were published in a peer-reviewed journal.

Alhafadhi, L., et al. (2020) [4] introduced a new method for lowering photovoltaic (PV) system THD by using a flexible filter based on a forecast model. a single-step approach is implemented rather than lowering THD created at each stage of the PV system, . Flexible filter , active and idle filters have the same flexibility. The option to alter the filtering coefficients sets it apart from others. The validity of the proposed technique is tested using the leaky LMS , LMS,

NLMS algorithms on a single-phase standalone photovoltaic system. Using all of the described techniques, the suggested approach may greatly minimize total harmonic distortion in the current signal of the photovoltaic system. The most efficient THD reduction is achieved with tiny step sizes and lengthy filters. NLMS minimize THD the greatest, whereas LMS achieves the peak current the quickest.

Awais, M., et al. (2016) [5] proposed the development of a novel problem as a developmental constraint and applied it to three parallel phase plans. They claim that THD reduction for single phase CMLIs, will result in a solution that differed from that of a three-phase system due to the presence of triple-n harmonics, which are not taken into consideration when the three-phase systems are balanced. This study applies the earlier proposed innovative formulation of a problem minimising total harmonic distortion in CMLIs to systems with only one phase, which was originally proposed for multiphase systems. It is shown by the computational findings , Total Harmonic Distortion minimization for single phase systems leads to a greater number of solutions with a higher value of total harmonic distortion when compared to three phase systems. Circuit simulations are used to verify the accuracy of the computational findings.

Bajaj, M., et al. (2020) [6] provided an overview of power quality problems that have arisen as a consequence of the increased use of renewable energy systems which are tied to the grid , then comes a short review of the modern technology solutions that have been published to alleviate those concerns. Furthermore, potential for future investigation into mitigating measures is thoroughly discussed.

Basit, M. A., et al. (2020) [7] presented a comprehensive review of renewable energy sources. The implementation of ESSs in renewable energy systems, as well as the development phase of these systems, has been explored. The importance of ESSs in extending the lifespan, improving efficiency, and increasing the energy density of power systems that use renewable energy sources has been examined. Furthermore, numerous strategies for resolving crucial challenges in photovoltaic (PV) systems, such as poor efficiency, harmonics, and inertia reduction, have been given. For the first time, this research explores the influence of FACTS technology on renewable energy-based power systems employing multitype flexible AC transmission system controllers, in contrast to the majority of the current review studies. Using the Open CL library, three simulation models were created in MATLAB/Simulink. Based on the findings, devices used in flexible AC transmission system contribute to the RES's stability integrated power system by increasing its efficiency. The work has the potential to benefit industrial as well as other discipline researchers to gain a better understanding of the challenges and strategies

for solving renewable energy systems, as well as the scope of future research in the field, through collaboration. .

Basta, B., & Morsi, W. G. (2021) [8] assessed the harmonic emission from fast-charging stations at both the low-order as well as high order harmonics. ESSs implementation in renewable energy systems, as well as the development phase of these systems, has been explored. The importance of ESSs in extending the lifespan, improving efficiency, and increasing the energy density of power systems that use renewable energy sources has been examined. Furthermore, numerous strategies for resolving crucial challenges in photovoltaic (PV) systems, such as poor efficiency, harmonics, and inertia reduction, have been given. For the first time, this research explores the influence of FACTS technology on renewable energy-based power systems employing multitype flexible AC transmission system controllers, in contrast to the majority of the current review studies.

Belega, D., & Petri, D. (2021) [9] proposed to measure the frequency, amplitude, and sine-wave phases influenced by wideband sound or both sound and harmonic purity. To their knowledge, the novel method of Corrected Interpolated Discrete Fourier transform (IpDFTc) estimates signal parameters first by compensating for the effect of visual distortion from the basic image component and compliance with the standard IpDFT parameters. Further a linear sine fit approach is employed to improve estimators' noise resilience, which is harmed by the use of signal windowing to decrease spectral leakage. The Hann window is used in the study because it has the best noise resilience and reduces long-range spectral leakage. Both suggested approaches virtually reach the Cramér-Rao Lower Bounds for unbiased estimators considering a minimum of 1.5 sine wave cycles are detected, allowing windowing to successfully correct for interfering tones on IpDFTc estimates. Both approaches' performances are evaluated using computer simulations and experiments.

Biswas, P. P., et al. (2017) [10] proposed an approach based on a differential evolution (DE) algorithm called L-SHADE to optimize Hybrid active power filter (HAPF) parameters. For a restricted multimodal nonlinear objective function, SHADE is the effective historical adaption strategy used in DE. L-SHADE enhances SHADE's performance by lowering population size across generations. The paper covers two popular HAPF topologies for parameter estimation. Harmonic pollution is reduced in a non-linear sources system as well as loads using a single goal function combining VTHD and ITHD. An industrial facility is studied in detail. Previous research compared the L-SHADE algorithm's output to other well-known evolutionary algorithms.

Busatto, T., et al. (2020) [11] addressed the disparity between the result of frequently used model's and the actual

harmonic distortion measured in terms of input voltage of lower magnitude . To measure the indirect interaction between these two variables a variety of indicators are presented. It is possible to estimate the value of a commonly used model that is also capable of predicting the corresponding voltages in the modern low-voltage system using these indicators. Measurements taken from various combinations of photovoltaic inverter as well as LED lamps which use various technologies provide evidence-based evaluation of the proposed model and subsequent statistical analysis. The findings indicate that the difference is affected by technology implemented , the impedance of the network, as well as the waveform of the source voltage .Other discoveries include the fact that nonlinear interaction occurs mostly at lower harmonics as well as effects are more noticeable at the phase angle of the harmonics. These observations are examined in relation to possible reasons for them.

Chen, F., Ruijie, L., & Guanhua, L. (2019) [12] built a complete charger (station) model for evaluating the effects of charger number, charger power, and initial SOC on harmonics Then to reduce harmonics, APF is implemented. The approach makes use of a hybrid control strategy that includes both PI control and repeated control elements. The results of simulations confirms usefulness of the strategy that has been presented. The harmonic pollution caused by electric car charging stations is growing more and more significant as the number of electric vehicles on the road continues to increase. The ability to evaluate and manage the harmonics created during the charging process of electric cars is very important for safety reasons.

Elkholy, M. M., et al. (2018) [13] addressed the applications of passive filters in grid-connected and isolated hybrid renewable microgrids are addressed. In order to maintain overall demand distortions within the maximum permissible limits, use of single tuned filters is preferred . Total cost and total harmonic distortion of suggested passive filters define the modified bi-objectives that must be reduced concurrently within certain operational inequality constraints. A MOGOA is used here. Best Pareto solutions are chosen carefully using the TOPSIS (similarity to ideal solution) method. Before and after installing passive filters, harmonic analysis is used to check critical frequencies. Impact of harmonics on motor as well as torque of wind generator is examined in their work . The power factor of the system is also enhanced. Different grid operating scenarios are explored, including the uncertainty of renewable energy sources. Ripples present in the torque in induction motors as well as wind turbine generators are reduced. As compared to the results of the well structured multi objective genetic algorithm, the MOGOA cropped results of filter cost and THD are extremely competitive and compelling.

Etesami, M. H., Vilathgamuwa, D. M., Ghasemi, N., & Jovanovic, D. P. (2018) [14] compared prominent stochastic methods adopted for SHE and modified SHE (MSHE) PWM techniques. Issue is characterized as they search for optimum local in the operating parameters of cascaded H-bridge converters. The study specifically examines important indices of lower harmonic components as well as weighted overall harmonic distortion.. For SHE and MSHE, a floating fundamental component is included in order to gain a greater rate of flexibility for optimization procedures, which is beneficial. Finally, an enhanced modulation strategy is given to handle the ripples present in the voltage on dc-link circuit. For the purpose of demonstrating the idea, simulation and experimental findings are provided.

Fang, J., Deng, H., & Goetz, S. M. (2020) [15] proposed an impedance estimation method well suited to grid-forming converters. The approach is comprised of four operating modes, all of which are effective in voltage and power control applications. The instance of voltage control, the magnitude perturbation or phase angle is used to regulate the voltage. The grid inductance and resistance are then calculated based on the power measurement.. In the power control instance, on the contrary, the active or reactive power information is used to predict the grid impedance. The suggested technique has the advantage of being simple to apply and being free of harmonic distortion, safety concerns, and dependency on control settings. Furthermore, the approach is non-intrusive in the vast majority of circumstances. It is also recommended to use a unique Kalman filtering approach in order to give additional incentives. Finally, the results of simulations and experiments demonstrate that the suggested strategy is both successful and straightforward.

Ferreira, D. D., et al. (2015) [16] presented a new application of independent component analysis for the extraction of harmonic components from the signals of power system. In addition, since approach does not need synchronous sampling, it is capable of operating at frequencies other than the normal one. This allows it to function in off-nominal frequencies. In the operational stage, the suggested approach has been shown to be straightforward. Using both simulated and actual signals, the approach was put through its paces, and its performance was assessed using metrics that were measured in both the frequency as well as temporal domains. The outcomes were compared to those of another strategy that had been published in the literature.

Garrido, J., et al. (2018) [17] implemented the algorithms on a compact RIO controller using an FPGA and a real time processor. To compare the techniques, an system of investigation with a digitally controlled LED driver was put up. Worldwide standard-setting community is concerned with supra harmonic distortion where the frequency ranges from 2 to 150 kHz. Power electronics is widely accepted technology that is used in practically every electrical system.

This method reduces low frequency harmonic emission in the range of 2 kHz in power converters by moving them within the kilohertz region at the switching frequency as well as its multiples. The magnitude of spectral components is important while investigating electromagnetic interference from active power factor adjustment stages in modern LED drivers. Supra harmonics are currently causing many network issues. The standardizing organizations are currently upgrading the 2–150 kHz compatibility limitations. Supra harmonics operate differently than (lower frequency) harmonics. Fortunately, as this article will show, exploiting technologies like random pulse-width modulation allows us to tackle this problem from the start.

Gorbunov, R. L., & Poskonnyy, G. I. (2016) [18] presented the results of an accurate estimation of the previously proposed a mathematical model which is simplified for analysing distortion of harmonics in an alternating current Buck converter. This experiment is carried out with a power converter prototype that has been created in conjunction with an induction motor. According to digital signal processing theory, the findings of the experiment must be further processed in Matlab in accordance to the theory. The suggested model's accuracy is contrasted against the precision offered by a complicated model-based computer simulation to determine which is more accurate. As a consequence, it is strongly suggested that the model be employed in a variety of technical applications.

Goud, B. S., et al. (2021) [19] proposed the optimal power quality reinforcement in grid-connected hybrid renewable energy sources such as wind turbine , solar PV , battery storage which use an intelligent approach. The EVORFA method combines the Egyptian vulture optimization algorithm with the random forest algorithm . Their study aims to stabilize voltage, reduce power loss, and reduce harmonic distortion. The dataset of proportional parameters of integral gain is formed by EVOA; load current, DC link voltage, as well as sources of voltage that are based on reduced error objective function. EVOA considers many criteria related to power quality (PQ) concerns. Based on the achieved dataset, the RFA predicts the ideal control signal. The EVORFA technique is implemented in MATLAB/Simulink. The EVORFA technique works in two modes: PQ reinforcement ( $PRES > 0$ ) as well as power quality reinforcement ( $PRES = 0$ ). Then the experimental findings are contrasted with current approaches , GSA and RFA.

Hu, H., He, Z., et al. (2015) [20] examined the proliferation of high-speed locomotive-based trains resulting in significant alterations in current as well as voltage waveforms in power supply systems as well as operating system .The high-speed trains' dynamic nature makes assessing power-quality issues challenging. Techniques to measure the cumulative PQ consequences of contemporary trains over 24 hours are urgently needed. PQ evaluation uses

dynamic behavior modeling of current trains inbetween two station stops. The 24 hour train schedule and rail infrastructure profiles are used to calculate train locations, speeds, and power consumption. The measurement-based Norton equivalent model is developed into six sets for depicting the train's dynamic harmonic behaviour. Systemically modelled are the Scott connection transformer, utility system as well as traction lines. The proposed model is appropriate for evaluating the overall PQ impacts of HST dynamic behaviour as well as system topology which is involved in basic power flow as well as harmonic power flow.

Hu, H., Tao, H., et al. (2017) [21] introduced an entry-level impedance based model to look into the interoperability of multiple trains as well as traction network interactions with the goal of detecting critical factors for example low frequency oscillation, harmonic resonance as well as harmonic instability. A thorough coupling model is presented for analysing the three interacting phenomena, their features, important elements, analytical methodologies, and feasible mitigation measures. The measured waveforms of these three occurrences are initially described in Part I of the two-part article. The three difficulties are then investigated inside a train-traction network architecture. The electric trains and traction network's all-frequency impedance characteristics are modelled to elucidate the interaction mechanism. In which the train's impedance-based input behaviour is completely examined in DQ-domain. A frequency domain nodal matrix represents a traction network. In addition, the frequency scan method measures and validates the impedance frequency responses of both electric train as well as traction networks. The two-part article is completed with a generalised train network simulation as well as experimental system.

Ismael, S. M., et al. (2019) [22] provided for the first time, a systematic and extensive overview of the HC research, advancements, evaluation techniques as well as enhancement technologies. It is divided into four major parts: historical advancements, performance limitations, impressions, as well as augmentation strategies. The historical developments segment is divided into four sections: Apart from that, practical experiences of energy markets, system operators, as well as the results of real world case studies are provided as well as thoroughly examined. Finally, it had been determined that the achievement of integrating more dispersed generating is dependent on a precise estimate of available capacity for hosting.

Ivry, P. M., et al. (2017) [23] investigated the impact of uncertainties on the prediction of harmonics in a power system implementing multiple VSC's. Their research focuses on the forecasting of harmonic distortion levels in a variety of voltage source converters when a particular system or design factor is only known under certain

limitations. As an effective predictor of the amount of distortion in harmonic of the Voltage Source Converters measured at the PCC to the grid, the UDR approach was used in this investigation. Two case studies were investigated, and UDR approach was tested in an experimental setting to ensure that it was effective. A comparison was made between the acquired findings and the results of the Monte Carlo Simulation.

Jadeja, R., et al. (2015) [24] provided insight into the various mechanisms of variation in the pulse rate and their impact on the distribution of harmonic spectrum for a number of applications, including drives, hybrid electric vehicles as well as renewable energy sources, at two levels and a three-level inverter. It goes without saying that random pulse width modulation has several benefits, including noise reduction, electromagnetic interference suppression, and torque ripple (PWM). PWM converters with a multilayer topology are capable of meeting the highest quality requirements for power supply across the world. Additional benefits of the random PWM approach may be found here. One use is the equalization of switching losses in power switches for multilevel inverters (cascaded H-Bridge), among other things. Their research gives a thorough grasp of several random PWM approaches as well as their respective applications.

Jing, T., et al. (2019) [25] introduced a method for the selective harmonic elimination process selected using particle swarm optimization according to different inertia weights along a repetitive process that could avoid falling to a higher level and improve algorithm stability to determine global space size of the solution. The suggested system may rapidly generate a large number of switching pattern solutions, but existing approaches such as iterative techniques and resultant theory have a difficult time determining these solutions in a timely manner. These switching angles are computed offline by a computer in this case, taking into consideration the reduction of low-order harmonics. Theoretical findings for a (3L-NPC) neutral point clamped inverter having three level are investigated and confirmed via simulations in this paper. However, the total harmonic distortion and switching angle trajectory of the output voltage are distinct in the above-mentioned technique, as shown by the simulation results.

Kabalci, Y., et al. (2018) [26] proposed a harmonic estimation solution for power systems which are based on a modified artificial bee colony algorithm. Considering fact that the estimating procedures in their work are primarily focused on minimizing computing complexity and time, the suggested approach differs from other hybrid strategies that have been previously described. To improve the accuracy and comprehensiveness of the estimated findings obtained by the suggested technique, two independent experiments are being conducted and analyzed. Based on the results of the trials, it was discovered that the suggested harmonic

estimator has various benefits, including a very short calculation time, a more precise estimate of amplitude as well as phase values under all the possible circumstances, having a low level of complexity.

Kaddah, S. S., et al. (2016) [27] proposed new probabilistic PQ indices for electric grids including wind energy systems. The suggested PQ indices integrate discrete Markov analysis and wind speed probabilities with grid behaviour. The major suggested PQ indicators are flicker, harmonics, and sag in the voltage. Indices developed are useful for electrical networks with substantial wind power penetration. The approach may be utilized for additional power quality or system performance metrics. The percentage of renewable energy systems in future electric grids is predicted to rise to meet substantial demand shortages. Wind energy is a major source of renewable energy. The increasing use of wind energy conversion equipment in today's electric grid will unavoidably have an impact on power quality. Power quality (PQ) indices measure the power's quality. They are used to compare the harmful effects of various disruptions on electrical systems. Previous PQ index studies with wind energy systems were based on a constant wind speed. As a result, the PQ indices are instantaneous in nature. They are not representing the overall impact on power quality of grid connected energy plants which are working on wind energy.

Lamedica, R., et al. (2019) [28] based on demand conditions, proposed a new approach for modelling time varying loads (nonlinear) in power systems. By using a model, it is possible to do a preliminary assessment of harmonic distortions under the changing circumstances by using normal as well as uniform distribution to randomise electrical values of nonlinear loads as well as associated harmonic spectra. In order to test the model's performance, a measuring campaign was carried out in an industrial area, which served as a deposit / maintenance as well as repair site for trains operating on metro line B (situated in Rome). The results of this campaign were taken into consideration. The approach can be used to estimate the overall harmonic disturbances in the voltage signal at the PCC. The harmonic distortion distribution was examined using conventional normality tests, which were performed as part of the statistical analysis. The approach has also been used for pre evaluation disturbances of harmonics caused by the planned installation for charging stations used for of electrical cars.

Lucas, A., et al. (2015) [29] During the entire EV charging cycle, four sets of measurements were taken, and each harmonic amplitude and phase behaviour was examined. The TDD and THD for voltage and current were also computed and compared to IEEE519, IEC 61000/EN50160 standards. The harmonic phase angles of two rapid charging cars linked to the same feeder were also modeled. Their research found that total demand distortion was a much better indicator a compared to total harmonic distortion

because TDD uses the maximum current and THD uses the fundamental current, which may result in incorrect results. The 11th and 13th harmonics failed to meet the 5.5 percent restriction in IEEE 519. (5 percent, 3 percent in IEC 61000). Preferred range variations from the fundamental wave. The average phase angle variation across vehicles attached to the same feeder was determined to be less than 90°. Increasing the number of cars (IL) reduces the standard limits, which finally exceeds them due to the upstream short circuit current. Harmonic constraint comes first, ahead of the power limitation. First restriction on chargers is not the upstream power circuit's power capacity, but it is harmonic pollution limitations.

Lyon, J. D., et al. (2016) [30] investigated the benefits of corrective switching using authentic Independent System Operator of New England data as well as software to address most recent TS challenges. Hence, their findings as well as analysis outperform any other research done so far. TS is used as a preventative measure in dependability applications. ISO NE ensures N-1 reliability by imposing proxy reserve requirements and N-1 reliability by enforcing preventative dispatch. Their approach uses TS as a correction mechanism for both N-1 as well as N-1-1 events. Using authentic market data and proprietary market software, ISO-NE investigates not just corrective switching's capacity to ease thermal overloads but also its economic advantages. The findings suggest that corrective TS can increase system dependability and millions of dollars can be saved per year by replacing ISO-NE. Findings also show TS might assist systems having larger transmission congestion, for example Pennsylvania, Maryland, New Jersey, MISO, and the Electric Reliability Council of Texas.

Madichetty, S., et al. (2016) [31] demonstrated the first use of a novel Modular Multilevel Converter based Series Compensation technique for a multi area Automatic Generation Control interconnected system. The converter based series compensation model, which is primarily in state space form, suggests an adequate position in AGC for achieving improved dynamic responses in frequency, tie-line power, and individual generating power, as well as the suppression of oscillation caused by rapid changes in load. The functioning of the MMCS system has been explored, as well as the Generation Rate Constraints of the reheat turbines that are employed in the system, in detail. A second investigation into the selection of suitable integral and proportional-integral controller gains for step load perturbation in area 1 was conducted using the Integral Square Error technique and the Particle Swarm Optimization technique, with the performance index serving as the objective function and the control parameters being treated as variables. The performance of a system with MMCS is compared to a system without converter based series compensation, and it is observed that the

performance was improved, with the findings being discussed.

Marquez, A., Leon, J. I., et al. (2019) [32] focused on a CHB working with conditions which are not balanced per cell. If the phase-shifted pulse width modulation approach is used in this situation, it results in harmonic distortion that is about two times the carrier frequency as well as its multiples in the CHB output voltage. In their study, they develop an extended variable angle PS-PWM approach as well as alleviate this issue while also enhancing the spectrum of harmonic of the CHB output voltage. The suggested approach applies an algorithm which uses a mathematical investigation into identifying the phase displacement angles that should be applied to the PS PWM technique before implementing the algorithm. The experimental findings demonstrate that this goal may be reached without causing any disadvantages in the functioning of the CHB system. Using this approach, you may create a CHB with whatever amount of cells you choose.

Martinek, R., et al. (2019) [33] studied the use of least mean squares and recursive least squares algorithms for THD reduction using shunt active power filter control. A prototype for own controlled adaptive modular inverter is exhibited. The research's goal is to determine the best implementation algorithm. The introduction describes current methodologies and surveys the literature. Only adaptive filtering meets our needs, says this study (adaptability, real-time processing, etc.). Their work focuses on the efficiency of two fundamental adaptation strategies least mean square and recursive least square in the context of SAPF control. Study looks into how parameter choices (convergence constant, forgetting factor and filter length) affect Total Harmonic Distortion, SNR, RMSE, PRD, speed, and stability. The tests use genuine current and voltage records (HI-FI amplifier, PC source without PFC etc.) that feature rapid transient dynamic events. The real model accounts for DSP (about 1–5 s) and inverter response time (roughly 100 s). In the pilot project, the RLS method was found to be the best fit for developing an adaptive modular inverter.

Maruthupandi, P., et al. (2015) [34] tried to improve energy quality by lowering the content of harmonics at the output voltage of a high-level variable converter using the SHEPWM technique. The switching signals are generated using the sinusoidal pulse width modulation approach. To accomplish the decrease in harmonic components present in output voltage, a single phase cascaded MI having nine-level and an identical supply (DC) has been developed and tested. In order to identify the optimal switching angles, the particle swarm optimization approach is used, which results in the reduction of certain higher order harmonics, keeping necessary fundamental voltage. Using the expanded method, multilayer inverters with any number of layers may be created. For various modulation indices, the total

harmonic distortion measured in the same way as before. The design, fabrication, and testing of a prototype of a 9 level inverter based on a field programmable gate array have been completed. Thus, the findings of the simulation are compared with those of the hardware and a conclusion is drawn from this.

Massrur, H. R., et al. (2016) [35] proposed a new approach for minimization of total harmonic distortion (THD) of a multilevel flying capacitor inverter based on the selective harmonic elimination named stochastic total harmonic distortion strategy. Stochastic total harmonic distortion method considers the multilevel inverter's step voltage levels as fluctuating owing to imbalanced capacitor voltages. Their approach further enhances harmonic elimination modeling by including dissipative snubbers, blanking time, gate-drive circuits, and microcontroller computation time. The cited causes cause switching times to diverge from planned times. The fluctuations in the switching angle as well as flying capacitor unbalancing voltages are estimated using a  $2m + 1$ -point method. A novel robust approach for minimizing THD is created by combining the formulation with an improved cuckoo search algorithm and self-adaptive mutation strategy. With low switching frequency and no controller, the suggested STHD technique can determine the optimal switching angles pattern. The suggested solution reduces particular harmonics with low THD on three MFCIs.

Montoya, F. G., et al. (2018) [36] used an advanced model to address critical aspects in retrieving the available data from publications about power quality as well as analysing the information using graph visualisation software as well as various statistical tools. According to findings, researchers' primary research interests are in the study of power quality issues as well as the development of mitigation strategies. Apart from these the other findings are significant cooperation networks among researchers inside as well as in addition to nations, according to the researchers. Research in power quality is concerned with the appropriate functioning of electronics and technical equipment in the industrial, service, and home sectors. The degree of power quality in an electrical system is decided by varying frequency, voltage, as well as waveforms in relation to the referred values. Disturbances of varying severity, which includes the following: power fluctuations, interruptions, and transients, correlate to these variances. Several studies have been conducted with the goal of identifying and analyzing power quality concerns. The study of current issues as well as the scientific cooperation network that underpins the subject of power quality, on the other hand, has been underrepresented in the literature.

Nademi, H., et al. (2017) [37] The revolutionary design power architectures into electric aircraft systems are being discussed in order to deal with issues of current developments. Despite larger on-board power needs, the

MEA concept's two challenging goals are improved power quality and enhanced redundancy. Their work explains functioning of multilevel three phase shunt filter (active) . used in upcoming MEA distribution power systems. The new shunt active filter uses a modular multilayer converter to compensate for harmonic current. Using a finite control set model predictive control approach, a current SAF control strategy is constructed. With a diverse range of current frequencies, accurate copy of the harmonic current on the supply side above a certain forecast area, and a modular structure with redundancy, the created technology brings various benefits to the aircraft electrical networks. With integrated disruption analysis and a quadratic system sequence solution, a special forecasting control system helps to improve performance time performance and bar sensitivity. Strong behaviour to manage harmonic currents in relation to impedance as well as basic frequency fluctuations are obtained when levels of consistent deviation meet the requirements of IEEE Standard 519.

Omar, A. I., et al. (2019) [38] introduced a novel contribution to a less complex control scheme for controlling voltage of DVR (dynamic voltage restorer). The suggested method improves power quality by increasing bus voltage, stabilising bus voltage, and minimising harmonic distortions using an error driven proportional integral derivative controller. Power imbalances, various error situations, and harmonic distortions of the energy system are avoided using this technology. PID acquisition settings are tuned using the locust optimization algorithm (GOA). Initially, suggested DVR controller was compared with a partial order PID . The small global error of the proposed control and the rapid variable response is achieved by comparing the performance of four development strategies: GOA, Cuckoo Search, Flower pollination, as well as Gray wolf optimizer. Second, a comparison of the results obtained after simulation utilizing the suggested controller with an active disturbance rejection controller shows optimum PID outperforms the ADRC. Finally, time-domain simulations in MATLAB were performed for evaluating the effectiveness of the suggested DVR and controller.

Pereira, H. A., et al. (2017) [39] investigated the characteristics of inverter impedance models when used in harmonic integration studies The method for estimating harmonic current contribution as a function of background harmonic voltage components is described in detail below. On the basis of detailed and average models, time-domain simulations are performed and compared to the impedance model created in the frequency domain. The presence of harmonic voltages in grids, impedance models are able to accurately estimate the current distortion for all active power injection situations. Measurements taken at a 1.4 MW PV plant connected to a distributed grid are also used to validate the simulation based on impedance models under a variety of power injection and harmonic voltage profile conditions.

The findings confirm that impedance models are capable of accurately representing the harmonic current generated by PhotoVoltaic plants at the PCC, notwithstanding their limitations. Finally, a stress test is carried out to demonstrate how changing the phase angle of the harmonic voltage affects the harmonic emission from a PV power plant.

Ravikumar, S., et al. (2020) [40] introduced a new phase for power quality output by analysing three DC to DC converters. A hybrid power generating system using a mix of solar and wind energy, converters and an inverter (full-bridge), is proposed in this study in order to decrease Total Harmonic Distortion (THD). This is accomplished by connecting DC to DC level converters such as buck boost, Single Ended Primary Inductor Converter and Cuk converters. The proportional gain as well as integral gain parameters of the PI controller are adjusted as a significant contribution, resulting in a reduction in total harmonic distortion (THD). They develop a new enhanced optimization method for this purpose, which they call the Fitness Oriented Rider Optimization Algorithm (FOROA), that is an improvement over the Rider Optimization Algorithm previously developed . When the proposed control system's optimum performance is compared to that of other traditional models, It demonstrates that the suggested work surpasses the other models.

Reddy, A. K. V. K., & Narayana, K. V. L. (2020) [41] presented a novel improved whale optimization algorithm for mitigating total harmonic distortion in multilevel inverters (IWOA). The IWOA is a natural optimization technique based on swarms. An extra ranking mechanism is used to determine the ideal option to reduce THD. THD reduction is also achieved by nine different meta-heuristic methods for inquiry and comparison. We evaluated the chosen algorithms' performance on single phase 5 as well as seven level H Bridge Multi Level Inverters ( cascaded )for consistency, computational economy, and convergence speed. The suggested approach surpasses nine techniques and is further efficient for total harmonic distortion reduction for multi-level inverters 0–1. Findings are examined and provided following MATLAB simulation.

Rönnerberg, S. K., et al. (2015) [42] summarized the state of part of the discussions in CIGRE/CIREN/IEEE joined working group C4. 24, particularly when it comes to supraharmonics. The worldwide smart grid standard-setting community is becoming more interested in understanding concerning distortion of harmonics for the range of frequency (2-150) kHz, which is known as supraharmonics. There were numerous exemplary installations and loads used to demonstrate waveform distortion measurements, which were provided. While it looks that equipment's supraharmonic emission is increasing as a consequence of the drop in emissions in lower frequency ranges, this is not



the case. Power electronics has developed as a pervasive technology that can be found in virtually any industry and plays a key role in almost every application. However, as noted in their study, power electronics converters may be a significant cause of waveform distortion, but when the appropriate technology is used, power electronics can also be a vital component in waveform distortion mitigation.

Rönnerberg, S. K., et al. (2017) [43] presented measurements of waveform distortion from several illustrative facilities and loads. Supraharmonics, according to recent research, may pose a threat to distribution grids in the foreseeable future. However, when approaches such as a random PWM or a modular multilevel converter are effectively implemented, grid-tie inverters may be a source of waveform distortion in this frequency range, but they can also be a pillar of mitigation. The worldwide standards community is presently examining the restrictions on supraharmonic distortion at the time of this writing. This is a group of harmonics that have frequencies ranging from 2 to 150 kHz in frequency. As a ubiquitous technology, power electronics has established itself as one that is also important in this field. In general, these high frequency components are produced by the regular functioning of the electronic converters as well as the switching mechanisms that are used.

Rönnerberg, S., & Bollen, M. (2016) [44] argued that with the advent of new methods of generating electricity, power, LED lights, underground cables, interferences would show up, along with an increase in distortion between 2 to 150 kHz called 'supra harmonics.' The shift in sound waves to frequencies of lower range may make up for some of carbon emissions at frequencies which are much higher, but interference transmission will be less predictable. Immunity of the equipment may also be unpredictable.

Stoyanov, I., et al. (2019) [45] conducted a comparative analysis and evaluation of the power output generated by a low-energy photovoltaic system. If the output voltage of a single phase of the solar inverter and still is measured using a power quality analyser, the main electrical power features and the harmonic spectrum of the active values in the outgoing current and voltage are still detected.

Tran, T. S., et al. (2019) [46] focuses on multi-island entities and seamless reconnection to the main grid as the livelihood within the future of energy system. Reducing energy quality concerns (especially those related to voltage, frequency, and harmonics) in regulated businesses, with or without communication, is also an important aspect of their job description. As the distribution generation grows, the future power system will be able to quickly adapt to any problems that arise within it separately into independent island businesses to avoid the dissolution of the DGs (distributed generation). Customers benefit from the high quality and consistent quality of electricity provided. Finally, future

research that will be needed on future energy system development is considered in detail.

Ul-Haq, A., et al. (2018) [47] studied the voltage assessment of THD that occurred as a result of single phase electric vehicle charging in urban as well as rural distribution networks. In their study, they looked at a complete harmonic distortion test caused by charging an electric motor in a low-voltage residential distribution network. CIGRE is a low-voltage distribution system used on the testing ground serves as the foundation for the sample test network. Simulations are carried out in order to determine voltage THD using a variety of current harmonic spectral densities. In conclusion, the observed findings imply that electric vehicles (EVs) may be distributed across the power grid without causing harmonic pollution to be a worry.

Velásquez, RMA, & Lara, J.V.M (2020) [48] provided a new testing process for power companies and equipment industries in the operating system, which will reflect the standards of compliance testing, in the standard assembly area (PCC). Real-world failure analysis was performed to better understand PCC concepts. It's critical to understand the flow of harmonic power as well as other parameters like maximum current, short circuit ratio, total demand distortion as well as total harmonic deviation. Now that you have a better understanding of the IEEE 519 standard, which states that size should be subject to temporary variability and properties related to statistics of the level of harmonics, among other things. Harmonics are essential because they affect levels and control of the utility system.

Wang, G., Gao, F., et al. (2020) [49] A hybrid islanding detection method for inverter based distributed generation units was proposed. They begin by conducting a thorough characteristic analysis as well as developing design guidelines for the hybrid inverter based DGs. This approach uses both passive and active methods to detect voltage imbalance as well as total harmonic distortion (BRPV). BRPV technique is turned on when the VU/THD method suspects islanding. This improves the islanding detection performance without affecting power quality. Their study also changes the usual VU/THD technique for rapid and precise detection and analyzes the threshold setting concept using an analogous circuit approach. The suggested technique outperforms the existing method for inverter-based distributed generating units. The suggested method's islanding detection performance was tested using simulation and experiments based on IEEE Std. 929 as well as IEEE Std. 1547.

Warrier, B. R., et al. (2021) [50] presented a preliminary investigation into the variational mode decomposition technique as a synchronizer for the grid for power converters in emerging electric grids having nonlinear characteristics. Several VMD modes as well as data-fidelity parameters are tuned to accomplish tighter fundamental

frequency separation despite spectral band changes and slight grid voltage frequency aberrations. The test cases are founded on CIGR and IEEE Task Force 1159.2 repositories for anticipated power quality issues in new utilities. The retrieved fundamental frequency signals are compared to the applied values using two statistical indices: absolute percentage error as well as RMS error. In the simulation, compared to traditional grid synchronizers, the tracking time was significantly reduced for all test situations. Even with various power quality concerns, significant accuracy is gained in monitoring the needed signal properties. The VMD synchronizer's frequency decomposition was protected from random momentary events including an increase in electrical power, zero-crossing disorders, phase and frequency fluctuations. Hardware authentication used imitation grid signals representing multiple power quality concerns and temporary events, and the results were compared to the simulation.

Researchers must integrate current research used to control and use real-world micro grids to improve these systems in order for the micro grid to develop faster in the future. As a result of this consideration, my research will focus on virtual reality micro grid built-in and experimental technologies in the VSC architecture interface, its switching strategy, and control methods, with special emphasis on building a model that ensures excellent PQ in micro grid. . Based on predictions made about the degree of harmonic distortion of micro grid converters used, as well as the impact of various factors affecting the harmonics produced, research and research on the quality of micro grid energy will be investigated. This will provide researchers and engineers with the ability to design a micro grid power assessment tool and build / use EPS within certain limits to ensure high energy quality.

### 3. Proposed Methodology

The section that follows provides a high-level overview of different key stages involved during the use of UDR approach to estimate harmonic distortion levels at a microgrid's Point of Common Coupling:

Step i): Identify all random variable functions in the system (for example, power and impedance) and calculate its possible distribution functions.

Step ii): To reduce the amount of variability, compute sigma and weight points using Univariate Dimension of UT-reduced Gaussian quadrature.

Step iii): Fill in the blanks with data from small grid system, which include sigma points and weights as obtained from from step ii .

Step iv): Simulation of micro grid can be used while collecting statistical data for output is recommended.

Step v): Calculate the output variables statistically with the help of marked output values as well as UDR weights (current rate / voltage THD / IHD, THD / IHD current / voltage standard deviation, and voltage THD / IHD standard deviation).

Step vi): Mathematical information on output variables is obtained .

### 4. Conclusion

It is concluded that to create clean energy and meet the consumer energy needs as well as protect rapidly depleted fuel depots the concept of small grid integration with Renewable Energy Systems into Power System provides a better solution. Renewables (RES) are frequently interconnected with the grid with the help of power converters for example Voltage Source Converters for power conversion and control. Both current and voltage harmonics are produced by the Voltage Source Converters (VSC) , have a negative influence on the Power Quality of micro grid and have potential to cause damage or mechanical failure to the equipment. The amount of harmonic distortion of many VSCs may be greatly influenced and difficult to forecast in the face of uncertainties, such as those caused by design parameter selection or system parameter changes. When dealing with VSC harmonic distortion levels in the face of uncertainty, statistical methodologies must be used.

### Acknowledgment

The main author is thankful to research guide, Prof. Dr. Prabodh Khampariya, Department of Electrical Engineering, School of Engineering, SSSUTMS, Sehore, for his guidance during the research work first review phase and also thankful to co-guide, Dr. Shashikant M. Bakre, Associate Professor, Department of Electrical Engineering, AISSMS (IOIT), Pune for technical help.

### References

- [1] Ahmed, E. M., Aly, M., Elmelegi, A., Alharbi, A. G., & Ali, Z. M. (2019). Multifunctional distributed MPPT controller for 3P4W grid-connected PV systems in distribution network with unbalanced loads. *Energies*, 12(24), 4799.
- [2] Ala, G., Caruso, M., Miceli, R., Pellitteri, F., Schettino, G., Trapanese, M., & Viola, F. (2019). Experimental investigation on the performances of a multilevel inverter using a field programmable gate array-based control system. *Energies*, 12(6), 1016.
- [3] Al-duaij, E. O. S. (2015). Harmonics effects in power system. *International Journal of Engineering Research and Applications*, 5(2), 1-19.

- [4] Alhafadhi, L., Teh, J., Lai, C. M., & Salem, M. (2020). Predictive adaptive filter for reducing total harmonics distortion in PV systems. *Energies*, 13(12), 3286.
- [5] Awais, M., Ilyas, H., Younus, H. B., Raza, M. A., & Abbas, T. (2016, December). Optimal switching angles for minimization of total harmonic distortion in single phase cascaded multilevel inverters. In 2016 19th International Multi-Topic Conference (INMIC) (pp. 1-6). IEEE.
- [6] Bajaj, M., Aggarwal, S., & Singh, A. K. (2020, February). Power quality concerns with integration of RESs into the smart power grid and associated mitigation techniques. In 2020 IEEE 9th Power India International Conference (PIICON) (pp. 1-6). IEEE.
- [7] Basit, M. A., Dilshad, S., Badar, R., & Sami ur Rehman, S. M. (2020). Limitations, challenges, and solution approaches in grid-connected renewable energy systems. *International Journal of Energy Research*, 44(6), 4132-4162.
- [8] Basta, B., & Morsi, W. G. (2021). Low and high order harmonic distortion in the presence of fast charging stations. *International Journal of Electrical Power & Energy Systems*, 126, 106557.
- [9] Belega, D., & Petri, D. (2021). Fast procedures for accurate parameter estimation of sine-waves affected by noise and harmonic distortion. *Digital Signal Processing*, 114, 103035.
- [10] Biswas, P. P., Suganthan, P. N., & Amaratunga, G. A. (2017). Minimizing harmonic distortion in power system with optimal design of hybrid active power filter using differential evolution. *Applied Soft Computing*, 61, 486-496.
- [11] Busatto, T., Ravindran, V., Larsson, A., Rönnerberg, S. K., Bollen, M. H., & Meyer, J. (2020). Deviations between the commonly-used model and measurements of harmonic distortion in low-voltage installations. *Electric Power Systems Research*, 180, 106166.
- [12] Chen, F., Ruijie, L., & Guanhua, L. (2019, November). Research on harmonic analysis and harmonic suppression measures of electric vehicle charging station. In 2019 IEEE 2nd International Conference on Automation, Electronics and Electrical Engineering (AUTEEE) (pp. 71-75). IEEE.
- [13] Elkholy, M. M., El-Hameed, M. A., & El-Fergany, A. A. (2018). Harmonic analysis of hybrid renewable microgrids comprising optimal design of passive filters and uncertainties. *Electric Power Systems Research*, 163, 491-501.
- [14] Etesami, M. H., Vilathgamuwa, D. M., Ghasemi, N., & Jovanovic, D. P. (2018). Enhanced metaheuristic methods for selective harmonic elimination technique. *IEEE Transactions on Industrial Informatics*, 14(12), 5210-5220.
- [15] Fang, J., Deng, H., & Goetz, S. M. (2020). Grid impedance estimation through grid-forming power converters. *IEEE Transactions on Power Electronics*, 36(2), 2094-2104.
- [16] Ferreira, D. D., Nagata, E. A., Ferreira, S. C., de Seixas, J. M., Duque, C. A., Marques, C. A., ... & Cerqueira, A. S. (2015). Method based on independent component analysis for harmonic extraction from power system signals. *Electric Power Systems Research*, 119, 19-24.
- [17] Garrido, J., Moreno-Munoz, A., Gil-de-Castro, A., Pallares-Lopez, V., & Morales-Leal, T. (2018). Supraharmonics emission from LED lamps: A reduction proposal based on random pulse-width modulation. *Electric Power Systems Research*, 164, 11-19.
- [18] Gorbunov, R. L., & Poskonnyy, G. I. (2016, June). Experimental verification of the simplified mathematical model for harmonic distortion analysis in AC buck converter. In 2016 17th International Conference of Young Specialists on Micro/Nanotechnologies and Electron Devices (EDM) (pp. 433-440). IEEE.
- [19] Goud, B. S., Rao, B. L., & Reddy, C. R. (2021). An intelligent technique for optimal power quality reinforcement in a grid-connected HRES system: EVORFA technique. *International Journal of Numerical Modelling: Electronic Networks, Devices and Fields*, 34(2), e2833.
- [20] Hu, H., He, Z., Wang, K., Ma, X., & Gao, S. (2015). Power-quality impact assessment for high-speed railway associated with high-speed trains using train timetable—Part II: Verifications, estimations and applications. *IEEE Transactions on Power Delivery*, 31(4), 1482-1492.
- [21] Hu, H., Tao, H., Blaabjerg, F., Wang, X., He, Z., & Gao, S. (2017). Train-network interactions and stability evaluation in high-speed railways—part i: Phenomena and modeling. *IEEE Transactions on Power Electronics*, 33(6), 4627-4642.
- [22] Ismael, S. M., Aleem, S. H. A., Abdelaziz, A. Y., & Zobaa, A. F. (2019). State-of-the-art of hosting capacity in modern power systems with distributed generation. *Renewable energy*, 130, 1002-1020.
- [23] Ivry, P. M., Oke, O. A., Thomas, D. W., & Sumner, M. (2017). Predicting harmonic distortion of multiple converters in a power system. *Journal of Electrical and Computer Engineering*, 2017.
- [24] Jadeja, R., Ved, A., & Chauhan, S. (2015). An Investigation on the performance of random PWM controlled converters. *Engineering, Technology & Applied Science Research*, 5(6), 876-884.
- [25] Jing, T., Maklakov, A. S., & Gasiyarova, O. A. (2019, January). Research on selective harmonic elimination technique based on particle swarm optimization. In 2019

- IEEE Conference of Russian Young Researchers in Electrical and Electronic Engineering (EIConRus) (pp. 694-700). IEEE.
- [26] Kabalci, Y., Kockanat, S., & Kabalci, E. (2018). A modified ABC algorithm approach for power system harmonic estimation problems. *Electric power systems research*, 154, 160-173.
- [27] Kaddah, S. S., Abo-Al-Ez, K. M., Megahed, T. F., & Osman, M. G. (2016). Probabilistic power quality indices for electric grids with increased penetration level of wind power generation. *International journal of electrical power & energy systems*, 77, 50-58.
- [28] Lamedica, R., Ruvio, A., Ribeiro, P. F., & Regoli, M. (2019). A Simulink model to assess harmonic distortion in MV/LV distribution networks with time-varying non linear loads. *Simulation Modelling Practice and Theory*, 90, 64-80.
- [29] Lucas, A., Bonavitacola, F., Kotsakis, E., & Fulli, G. (2015). Grid harmonic impact of multiple electric vehicle fast charging. *Electric Power Systems Research*, 127, 13-21.
- [30] Lyon, J. D., Maslennikov, S., Sahraei-Ardakani, M., Zheng, T., Litvinov, E., Li, X., ... & Hedman, K. W. (2016). Harnessing flexible transmission: corrective transmission switching for ISO-NE. *IEEE Power and Energy Technology Systems Journal*, 3(3), 109-118.
- [31] Madichetty, S., Dasgupta, A., & Kumar, L. S. (2016). Application of modular multilevel converter for AGC in an interconnected power system. *International Journal of Electrical Power & Energy Systems*, 74, 293-300.
- [32] Marquez, A., Leon, J. I., Monopoli, V. G., Vazquez, S., Liserre, M., & Franquelo, L. G. (2019). Generalized harmonic control for CHB converters with unbalanced cells operation. *IEEE Transactions on Industrial Electronics*, 67(11), 9039-9047.
- [33] Martinek, R., Rzigly, J., Jaros, R., Bilik, P., & Ladrova, M. (2019). Least mean squares and recursive least squares algorithms for total harmonic distortion reduction using shunt active power filter control. *Energies*, 12(8), 1545.
- [34] Maruthupandi, P., Devarajan, N., Sebasthirani, K., & Jose, J. K. (2015). Optimum control of total harmonic distortion in field programmable gate array-based cascaded multilevel inverter. *Journal of Vibration and Control*, 21(10), 1999-2005.
- [35] Massrur, H. R., Niknam, T., Mardaneh, M., & Rajaei, A. H. (2016). Harmonic elimination in multilevel inverters under unbalanced voltages and switching deviation using a new stochastic strategy. *IEEE transactions on industrial informatics*, 12(2), 716-725.
- [36] Montoya, F. G., Baños, R., Alcayde, A., Montoya, M. G., & Manzano-Agugliaro, F. (2018). Power quality: Scientific collaboration networks and research trends. *Energies*, 11(8), 2067.
- [37] Nademi, H., Burgos, R., & Soghomonian, Z. (2017). Power quality characteristics of a multilevel current source with optimal predictive scheme from more-electric-aircraft perspective. *IEEE Transactions on Vehicular Technology*, 67(1), 160-170.
- [38] Omar, A. I., Aleem, S. H. A., El-Zahab, E. E., Algablawy, M., & Ali, Z. M. (2019). An improved approach for robust control of dynamic voltage restorer and power quality enhancement using grasshopper optimization algorithm. *ISA transactions*, 95, 110-129.
- [39] Pereira, H. A., Freijedo, F. D., Silva, M. M., Mendes, V. F., & Teodorescu, R. (2017). Harmonic current prediction by impedance modeling of grid-tied inverters: A 1.4 MW PV plant case study. *International Journal of Electrical Power & Energy Systems*, 93, 30-38.
- [40] Ravikumar, S., Vennila, H., & Deepak, R. (2020). Hybrid power generation system with Total Harmonic Distortion minimization using improved Rider Optimization Algorithm: Analysis on converters. *Journal of Power Sources*, 459, 228025.
- [41] Reddy, A. K. V. K., & Narayana, K. V. L. (2020). Optimal total harmonic distortion minimization in multilevel inverter using improved whale optimization algorithm. *International Journal of Emerging Electric Power Systems*, 21(3).
- [42] Rönnerberg, S. K., Gil-de Castro, A., Bollen, M. H., Moreno-Munoz, A., & Romero-Cadaval, E. (2015, June). Supraharmonics from power electronics converters. In 2015 9th International Conference on Compatibility and Power Electronics (CPE) (pp. 539-544). IEEE.
- [43] Rönnerberg, S. K., Gil-de Castro, A., Moreno-Munoz, A., Bollen, M. H., & Garrido, J. (2017, April). Solar PV inverter supraharmonics reduction with random PWM. In 2017 11th IEEE International Conference on Compatibility, Power Electronics and Power Engineering (CPE-POWERENG) (pp. 644-649). IEEE.
- [44] Rönnerberg, S., & Bollen, M. (2016). Power quality issues in the electric power system of the future. *The electricity journal*, 29(10), 49-61.
- [45] Stoyanov, I., Iliev, T., Evstatiev, B., & Mihaylov, G. (2019, March). Harmonic distortion by single-phase photovoltaic inverter. In 2019 11th International Symposium on Advanced Topics in Electrical Engineering (ATEE) (pp. 1-4). IEEE.
- [46] Tran, T. S., Nguyen, D. T., & Fujita, G. (2019). The analysis of technical trend in islanding operation, harmonic

distortion, stabilizing frequency, and voltage of islanded entities. Resources, 8(1), 14.

[47] Ul-Haq, A., Perwaiz, A., Azhar, M., & Awan, S. U. (2018, March). Harmonic distortion in distribution system due to single-phase electric vehicle charging. In 2018 2nd International Conference on Green Energy and Applications (ICGEA) (pp. 205-209). IEEE.

[48] Velásquez, R. M. A., & Lara, J. V. M. (2020). Harmonic failure in the filter of Static Var Compensator. Engineering Failure Analysis, 107, 104207.

[49] Wang, G., Gao, F., Liu, J., Li, Q., & Zhao, Y. (2020). Design consideration and performance analysis of a hybrid islanding detection method combining voltage unbalance/total harmonic distortion and bilateral reactive power variation. CPSS Transactions on Power Electronics and Applications, 5(1), 86-100.

[50] Warriar, B. R., Vijayakumari, A., Palanisami, T., & Kottayil, S. K. (2021). An investigation on variational mode decomposition for synchronization of power converters in future power grids. Arabian Journal for Science and Engineering, 46(10), 9553-9572.

[51] A.O.Mulani and P.B.Mane, "An Efficient implementation of DWT for image compression on reconfigurable platform", International Journal of Control Theory and Applications, Vol.10 No.15, 2017.

[52] S. S. Swami and A. O. Mulani, "An efficient FPGA implementation of Discrete Wavelet Transform for image compression", International Conference on Energy, Communication, Data Analytics and Soft Computing (ICECDS), 2017

[53] A.O.Mulani and P.B.Mane, "Area Efficient High Speed FPGA Based Invisible Watermarking for Image Authentication", Indian Journal of Science and Technology, Vol.9. No.39, Oct. 2016.

[54] P. B. Mane and A. O. Mulani, "High Speed Area Efficient FPGA Implementation of AES Algorithm", International Journal of Reconfigurable and Embedded Systems, Vol. 7, No. 3, November 2018, pp. 157-165

[55] A.O.Mulani and Dr.P.B.Mane, "Fast and Efficient VLSI Implementation of DWT for Image Compression", International Journal for Research in Applied Science & Engineering Technology, Vol.5 Iss. IX, pp. 1397-1402, 2017.

[56] Pratima Amol Kalyankar, Altaf O. Mulani, Sampada P. Thigale, Pranali Gajanan Chavhan and Makarand M. Jadhav, "Scalable face image retrieval using AESC technique", Journal Of Algebraic Statistics Volume 13, No. 3, p. 173 – 176, 2022

[57] Dr. P. B. Mane and A. O. Mulani, "High throughput and area efficient FPGA implementation of AES algorithm", International Journal of Engineering and Advanced Technology, Vol. 8, Issue 4, April 2019

[58] A. O. Mulani and Dr. P. B. Mane, "Secure and area Efficient Implementation of Digital Image Watermarking on Reconfigurable Platform", International Journal of Innovative Technology and Exploring Engineering, Vol. 8, Issue 2, Dec. 2018

[59] Kulkarni P.R., Mulani A.O. and Mane P. B., "Robust Invisible Watermarking for Image Authentication", In Emerging Trends in Electrical, Communications and Information Technologies, Lecture Notes in Electrical Engineering, vol. 394, pp. 193-200, Springer, Singapore, 2017.

[60] A.O.Mulani and Dr.P.B.Mane, "Watermarking and Cryptography Based Image Authentication on Reconfigurable Platform", Bulletin of Electrical Engineering and Informatics, Vol.6 No.2, pp 181- 187, 2017

[61] A.O.Mulani and Dr.P.B.Mane, "Area Efficient High Speed FPGA Based Invisible Watermarking for Image Authentication", Indian Journal of Science and Technology, Vol.9. No.39, Oct. 2016. ISSN 0974-5645

[62] Kashid, M.M., Karande, K.J., Mulani, A.O. (2022). IoT-Based Environmental Parameter Monitoring Using Machine Learning Approach. In: Kumar, A., Ghinea, G., Merugu, S., Hashimoto, T. (eds) Proceedings of the International Conference on Cognitive and Intelligent Computing. Cognitive Science and Technology. Springer, Singapore. [https://doi.org/10.1007/978-981-19-2350-0\\_5](https://doi.org/10.1007/978-981-19-2350-0_5)