

“Hybrid MAC Methodology for Improving the Qos in Fiber Wireless Network”

Prabhjot Kaur^{1*}, Hardeep Singh Saini²

Submitted: 05/02/2024 Revised: 13/03/2024 Accepted: 19/03/2024

Abstract: The Fi-Wi (Fiber-Wireless) approach stands out as a crucial element in the realm of networks, demonstrating superiority over various technologies. With the exponential growth in Internet users, significant strides have been made in the evolution of Fi-Wi networking systems in recent years. This mechanism offers broader bandwidth and network stability, ensuring high-speed connectivity with "Anytime Anywhere" availability for end users. However, the escalating energy demand in networking systems poses a constraint on the network's lifespan, impacting transmission.

Over the years, researchers have proposed and tested various Media Access Control (MAC) protocols to address transmission and energy consumption issues. Despite these efforts, existing protocols have encountered challenges such as overheating, delays, throughput issues, and collisions. This research paper introduces a combination of Time Division Multiple Access (TDMA) and Carrier Sense Multiple Access (CSMA) to tackle associated challenges. The primary objective is to enhance throughput and reduce delays in Fi-Wi networks.

To achieve this goal, the study employs techniques that involve an Utilizing an Orthogonal Frequency Division Multiplexing (OFDM) modulator, a free-space optical (FSO) communication channel, an OFDM demodulator, and Opti-system for the analysis and enhancement of received signals, our study demonstrates that the proposed MAC protocol surpasses conventional MAC protocols in terms of delay, data throughput, and transmission efficiency.

Index Term- Fi-Wi, Media Access Control protocols fusion, Energy-Efficient Transmission, TDMA-CSMA Integration, CSMA,, FSO communication.

1. Introduction

The ongoing trend in internet and communication systems revolves around achieving ubiquitous access to information anytime, anywhere, and of any type. Wireless and optical advancements play pivotal roles in realizing this goal, with both systems seen as complementary. Fiber optics, while unable to reach every location, offer substantial bandwidth where deployed. On the other hand, wireless access networks have the flexibility to cover virtually any area but come with bandwidth limitations and susceptibility to various issues. Addressing the increasing capacity demands from consumers requires the seamless integration of both modalities, leading to the emergence of fiber-wireless (Fi-Wi) networks [1]. These networks represent an innovative approach that combines the strengths of wireless and optical fiber technologies. As the costs associated with optical fiber deployment are significant and free-space optical communication (FSO) networks have limitations, there is a growing push to

advance Fiber-Wireless (Fi-Wi) networks. The primary objective of this network is to enhance the ubiquity and mobility of wireless sub-networks, such as Wi-Fi and WiMAX, while simultaneously reducing the cost and complexity inherent in optical fiber sub-networks, including passive optical networks (PONs) [2]. In a conventional Fi-Wi network, an extensive array of PONs is utilized due to their ability to operate on a high-frequency spectrum, employing various advanced multiplexing techniques and photonic equipment to offer increased bandwidth, security, reliability, and immunity against electromagnetic interferences (EMI) [3]. PON, conversely, lacks flexibility and is incapable of responding to access queries promptly at specific times and locations. Users can gain advantages from wireless mesh networks (WMN) due to their cost-effectiveness and adaptable access. As a result, Fi-Wi networks optimize the utilization of PONs and WMNs, harnessing the optical network in the backend and wireless networks in the frontend to provide seamless access to end-users.

¹*Research Scholar, I.K.G. Punjab Technical University, Jalandhar, Punjab, INDIA,

Email ID: prabhjot.chanana@bbsbec.ac.in

² Professor, Indo Global College of Engineering, Abhipur, Mohali, Punjab,

Email ID: hardeep_saini17@yahoo.co.in

*Corresponding Author: Prabhjot Kaur

Email ID: prabhjot.chanana@bbsbec.ac.in

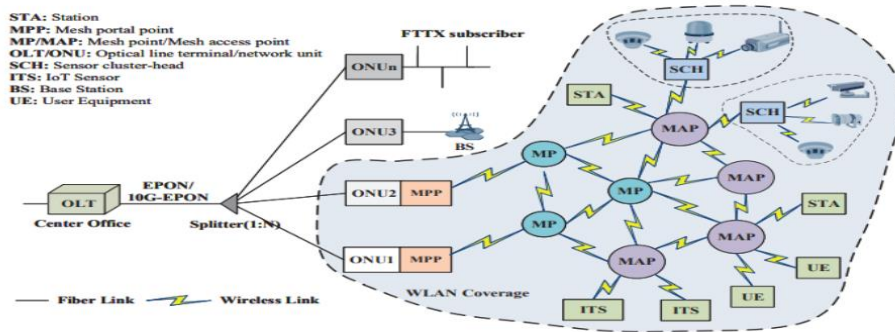

Figure 1. General architecture of Fi-Wi networks

1.1 Fi-Wi Network Architecture

Figure 1 displays the traditional configuration diagram of a Fi-Wi network. The optical backend comprises an optical line terminal (OLT) in a central office or CU, linking optical network units (ONUs) through an optical splitter. Concurrently, the front end utilizes the 802.11 WLAN architecture featuring numerous wireless routers, a mesh point (MP) serving as a data relay router, and the mesh access point (MAP) functioning as an end-user access point. Certain user-generated data is transmitted directly to Optical Network Units (ONUs) through optical fiber, subsequently relayed to the Optical Line Terminal (OLT) by the ONUs. The remaining data routes to the wireless mesh network (WMN) via the MAP, reaching integrated ONUs through multiple MPs (ONU-MPP). Consequently, the information is transmitted to the backend via the OLT. As shown in Figure 1, some ONUs offer connected FTTX service, while the second cluster connects to a base station (BS) for seamless access. Mesh portal points (MPPs) on the third subgroup of ONUs provide wireless connectivity to WLAN clients. To establish an internet connection, customer data is first sent to a nearby wireless router, relayed to the individual's primary ONU through a multi-hop wireless connection using wireless gateways. In due course, the package eventually reaches the Optical Line Terminal (OLT) through optical fiber, entering the internet infrastructure. The network then provides service to the user in the opposite direction [4-5]. The fiber-wireless network encompasses Passive Optical Networks (PONs) and Wireless Mesh Networks (WMNs), each possessing distinct characteristics in the transmission of data packets.

1.2 Enabling technologies in Fi-Wi

In the Radio over Fiber (RoF) framework, a range of radio wave frequencies traverse economical Remote Antenna Units (RAUs) and fiber optics, connecting central stations to facilitate diverse wireless applications. The significant propagation delay in fiber optics, while advantageous, can lead to heightened timeouts in MAC protocols, negatively impacting both delay and throughput. MAC systems that

rely on centralized polling and scheduling, such as the IEEE 802.16 WiMAX, demonstrate a lesser impact from increased propagation delays. This is attributed to interleaved scheduling and upstream polling transmissions that effectively coordinate long communication paths between the Center Office (CO) and Stations (STAs). In contrast, distributed medium access control protocols encounter challenges associated with propagation delays across Stations and Access Points (APs). However, the integration of optical distribution networks in Wireless Networks (WN) can significantly enhance the efficiency and effectiveness of MAC protocols [6]. Meanwhile, R&F systems address RoF limitations, utilizing both wireless and optical mediums with various MAC protocols for different applications.

2. Mac Protocols

The MAC protocol serves as a crucial connectivity protocol for device-to-device communication, significantly impacting system performance in terms of energy consumption, latencies, and other key factors. In Wireless Sensor Networks (WSN), the primary objective is to extend the network's longevity, as sensor nodes are expected to become non-operational once their battery is depleted. Examining the diverse interaction patterns inherent in Sensor Networks applications is crucial, as these patterns directly influence the behavior of sensor network traffic. A designated MAC protocol effectively manages this traffic, with a focus on energy efficiency to address the outlined energy losses below [7].

2.1 Energy wastage in MAC protocols:

Wastage of energy in Media Access Control protocols for Wireless Sensor Networks can occur due to several reasons. Some of these factors include the following:

Eavesdropping is a phenomenon where nodes may inadvertently intercept messages meant for different nodes, causing increased energy consumption. Techniques like Sensor-MAC, Timeout-MAC, and Convergent-MAC are effective in curbing excessive energy usage during idle periods. SMAC, a traditional

approach to scheduling wake-ups, employs a predetermined duty cycle to achieve energy efficiency.

Duty cycle = Listen interval/ Frame length

SMAC (Sensor-MAC) and TMAC (Timer-MAC) employ synchronized planning to minimize energy consumption, necessitating periodic synchronization. In contrast, CMAC (Coordinated MAC) supports reduced latency and synchronization overhead through the implementation of non-synchronized sleep scheduling, enabling efficient operation at very low duty cycles.

Control packet overhead- Transmission and reception of control messages require additional energy, leading to a reduction in the transmission of valuable data packets.

Collision: In the course of transmission, packets may encounter distortion, necessitating their rejection and subsequent resend, leading to increased energy consumption.

Idle Listening: - Scanning for potential undelivered traffic entails utilizing extra energy.

2.2 Taxonomy of MAC Protocols

The MAC can be broadly categorized into schedule-based MAC protocols and contention-based MAC protocols. Schedule-based technologies are limited by time synchronization challenges due to various factors. These protocols carefully strategize their transmissions, including wait times to tackle concerns such as collisions, overhearing, and idle listening. In contrast, contention-based methods eliminate the necessity for time synchronization, enabling swift adaptation to topological changes by integrating new stations. Nevertheless, some of these methods may face the challenge of potential degradation after several years of operation. Despite the multitude of MAC layer methods developed for sensor networks, each application presents unique challenges. Consequently, the selection of MAC protocols tends to be application-dependent, highlighting the absence of a standardized MAC for WSN applications [8]. Taking these considerations into account, numerous researchers propose diverse MAC protocol approaches to extend the lifespan of WSN while simultaneously reducing energy consumption by sensor nodes.

3. Literature Survey

In [9], researchers introduced a Fi-Wi access network employing Energy Efficient Ethernet (EEE) to optimize the performance and video applications of fiber-wireless networks, yielding promising outcomes. Additionally, [10] presents a novel approach to a sustainable and forward-looking Fiber-wireless network with sensor enhancement (Sensor FiWi), integrating fiber optic sensor (Fiber OS), wireless sensor (WS), WLAN, and EPON

technologies.. This innovative solution is specifically designed for smart grids and broadband access, showcasing noteworthy outcomes. In [11], an examination of a Fi-Wi access network was undertaken, incorporating fiber optic sensor and wireless components to enhance survival methods. The focus of the study was on IEEE-FiWi access networks, assessing elements such as consistency, versatility, and potential. Concurrently, in [12], researchers explored a MAC protocol for RoF-WLAN utilizing CSMA/CA, conducting tests on IEEE 802.11a/b/g WLANs. The experiment's outcomes indicated a significant improvement in TCP throughput. Furthermore, [13] addressed traffic control and energy efficiency by implementing an adaptive MAC protocol. Nodes were categorized into two priority groups based on transmission packet delay and traffic rates, yielding superior results compared to alternative approaches.

In [14], the authors extensively examined the factors contributing to diminished throughput through a series of experiments. Subsequently, they introduced an innovative control technique to enable users to establish high-throughput connections with access points (APs). Meanwhile, in [15], the focus was on investigating diverse methods aimed at neighboring users. The study harnessed cutting-edge, awareness-enhanced technology facilitating communication between buyers and sellers.

Moreover, the experts referenced in [17] proposed a reconfigurable architecture for 5G centralized radio access networks, specifically designed for Fi-Wi networks. The primary objective of this suggestion is to optimize spectrum allocation, ultimately improving the effectiveness and efficiency of these systems. Furthermore, [19]A Fi-Wi LAN architecture was introduced with a focus on energy efficiency, incorporating a demand strategy. Experimental findings demonstrated a notable power savings of around 60 percent. A comprehensive literature survey reveals numerous approaches proposed by experts in recent years to enhance communication efficiency in Fi-Wi systems. Despite these efforts, many methods presented drawbacks that impeded overall performance. A major challenge was the heightened delay, which escalated with increasing channel traffic. This elevated packet delay negatively impacted the efficiency of the entire Fi-Wi system, rendering it more susceptible to distortions such as noise and multipath distortions. Additionally, the increased packet delay adversely affected the Quality of Service parameters in the communication network, further diminishing overall network performance. Furthermore, limited attention has been given to prioritizing nodes to extend the network's lifespan by reducing energy consumption. Given these findings, there is a compelling need to develop a novel approach that can effectively

address these issues and enhance the overall performance of the network.

4. Network Architecture

Figure 2 depicts the structure of the proposed MAC protocol. The transmission channel facilitates the transfer of data. Signal illumination and modulation using the MZM modulator require a 10dBm laser. It is imperative to calculate the incurred delay before transmitting these signals via free space optics (FSO). This uniform distribution supports effective and seamless communication, as all nodes travel nearly identical distances.

Following this step, each node undergoes the assignment of destination and priority, highlighting that data transfer will occur based on the established priorities. Once priorities are allocated to individual nodes,

communication commences. In our suggested approach, we designate specific time slots for each node to enhance communication effectiveness, employing the Time DMA concept.

After allocating time slots to individual nodes, the system verifies the preparedness of the prioritized node in conjunction with its designated time slot. Furthermore, it must ascertain that the channel experiences minimal traffic when the node is set to transmit data. If significant traffic is detected, the scheduling for the transmitting node is adjusted, and a new time slot is designated.

The CSMA principle is implemented in the handling of the signal, and once again, its latency is assessed. In the event of a collision detection, the broadcasting process is momentarily halted, a jam signal is transmitted, and subsequently, a random period is awaited before retransmission. The diminished delay in the transmitted signal is then conveyed through the Free-Space Optical (FSO) channel and received by the designated receiver.

At the reception site, a photodetector is employed to identify the optical signal and carry out demodulation through the utilization of an orthogonal frequency-division multiplexing demodulator (OFDM). Ultimately, the received signal is subject to performance analysis, considering various dependency factors.

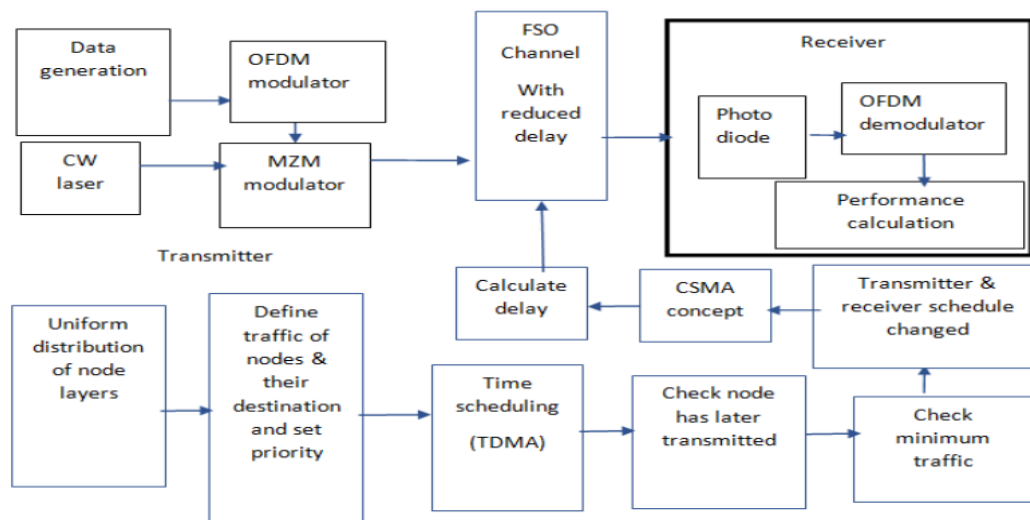

Figure 2. Proposed MAC protocol model

5. Present Work

In preceding sections, it has been emphasized that MAC protocols play a crucial role in optimizing the utilization of a shared transmission medium, directly impacting overall network performance. These protocols also address energy efficiency concerns by tackling issues such as idle listening, control packet overhearing, and collisions. To overcome limitations associated with traditional methods, this paper proposes a novel approach involving the hybridization of two MAC protocols: CSMA and TDMA. CSMA, or Carrier Sense Multiple Access, is characterized as a MAC protocol that assesses

the channel's status, determining whether it is busy or idle before initiating data transmission. On the other hand, Time Division Multiple Access (TDMA) is primarily employed for sharing access to the medium within a shared transmission range. It involves dividing channels of the same frequency into discrete slots that can be utilized by various stations. This simultaneous utilization of TDMA and CSMA presents a promising solution to enhance network efficiency and address the challenges posed by traditional methods.

In the TDMA process, the channel operates within the constraints of a super-frame structure comprising multiple time slots allocated by a coordinator. These time slots are

separated by a brief interval referred to as the guard period, serving to prevent potential conflicts in transmission between stations. Efficient communication is achieved when two stations synchronize faster than the guard time, ensuring collision-free interactions. To enhance the performance of the Fi-Wi model, our proposed approach combines CSMA and TDMA in a hybridized manner. The Fi-Wi network incorporates node

prioritization, emphasizing the proposed MAC protocol's core aim of reducing system packet delay and enhancing communication efficiency. The initiation of the model involves generating a random bit-form signal, subsequently modulated by an OFDM modulator before transmission over the FSO channel. In the proposed system's OFDM modulator, 128 sub-carriers are employed, employing QPSK modulation in Table below.

Table 1: OFDM parameters

Parameters	Values
No of Subcarriers	128
Cyclic Prefix Length	32
Modulation Type	QPSK
FFT Size	128

The nodes are evenly distributed throughout the network to ensure comprehensive coverage of the sensing region.

Following this, nodes are assigned priorities, with a primary emphasis on transmitting data initially by highly prioritized nodes. Prior to initiating data communication, the introduction of Time Division Multiple Access (TDMA) allocates specific time slots to each node, mitigating the risk of collisions. Moreover, the integration of Carrier Sense Multiple Access (CSMA) occurs at the Medium Access Control (MAC) layer to enable data transmission without collisions. Subsequently, signal delay is recalculated, and the data is transmitted to the receiving end of the model, where a photodetector detects it. The MATLAB-based proposed methodology is executed and evaluated in Opti-System for data scheduling, considering various performance metrics. The schematic of the transmission system within the proposed MAC system is elucidated in Fig. 3. Data, initially presented in bit form, undergoes modulation through the OFDM modulator. The Mach-Zehnder (MZ) modulator manipulates the signal using a laser operating at a frequency of 193.1 THz. In this work, a laser with a power of 10 dBm is employed to illuminate and alter the signal, which is then transmitted through the Free-Space Optical (FSO) channel. The depiction of data transmission through the channel is illustrated in Fig. 3. Figure 4 provides a schematic representation of the FSO channel, indicating a defined range of 1 km and an attenuation rate of 0.2 dB/km. FSO serves as the medium for transmitting the modulated signal to facilitate optical communication. Within the proposed system, the fundamental components responsible for data reception and transmission are the

receiver and transmitter, respectively. The receiver channel of the system is delineated in Figure 5. Following the delay calculation, the received signal undergoes evaluation based on various performance metrics such as throughput and delay. Additionally, the network nodes are assigned priority to enhance the efficiency and reliability of communication. Users with prioritization are allotted slots for data transmission in an effective manner.

6. Results And Discussions

The convergence of optical fibers and wireless networks within Fi-Wi networks seeks to attain optimal bandwidth for effective communication. The simulation parameters for Fi-Wi networks are specified in tabular format and presented in Table 2.

Table 2: Simulating Parameters for Fi-Wi Network

Parameters	Values
Bit Rate	10 Gbits
Sample Rate	640 GHz
Sequence Length	128 bits
Samples per bits	64
Number of Samples	8192
CW Laser Frequency	193.1 THz
CW laser Power	10dBm
FSO Range	1 Km
Attenuation	0.2 db/km
Transmitter Aperture diameter	5 cm
Receiver Aperture diameter	20 cm
Beam Divergence	2 mrad

To validate the effectiveness of the recently introduced MAC protocol system, its operational performance is evaluated within the Opti-system. Systematic experimental results are then compared with a specific set of conventional Fi-Wi techniques and MAC wired protocols. Assessment criteria encompass Q-factor, eye height, threshold, logarithm of bit error rate (BER) using Gaussian approximation, and additional Q-factor metrics. The rationale for comparing the proposed Fi-Wi MAC protocol network with its wired MAC protocol

counterpart is to comprehensively evaluate the efficiency of the proposed model in comparison to the established one. The simulation parameters utilized to examine the performance of the MAC wired protocol are detailed in Table 3. The subsequent section of this research paper concisely presents the obtained results for each parameter, offering insights into the comparative effectiveness of the proposed MAC protocol model versus the wired counterpart

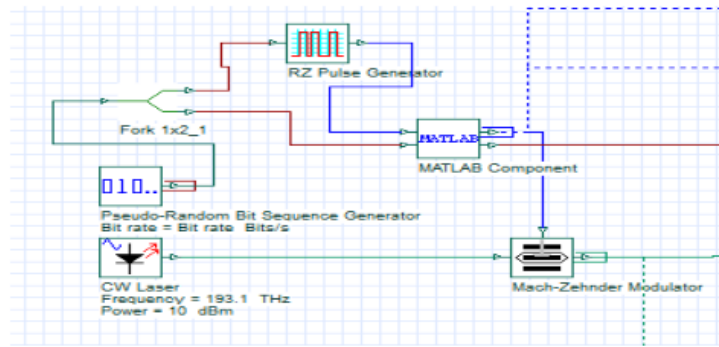

Figure 3. Transmission channel in proposed system

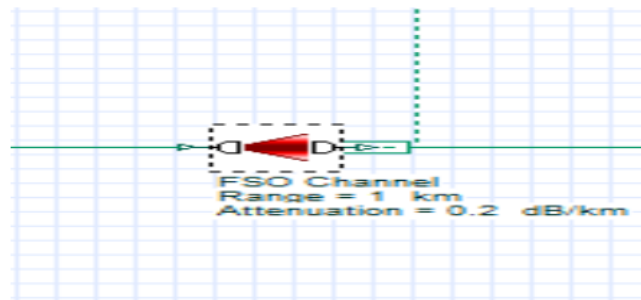

Figure 4. FSO channel

Table 3: Simulation Parameters Optical Fiber (Wired) Network

Parameters	Values
Bit Rate	10 Gbits
Sample Rate	640 GHz
Sequence Length	128 bits
Samples per bits	64
Number of Samples	8192
CW Laser Frequency	193.1 THz
CW laser Power	10dBm
Optical Fiber Range	1 Km
Attenuation	0.2 db/km

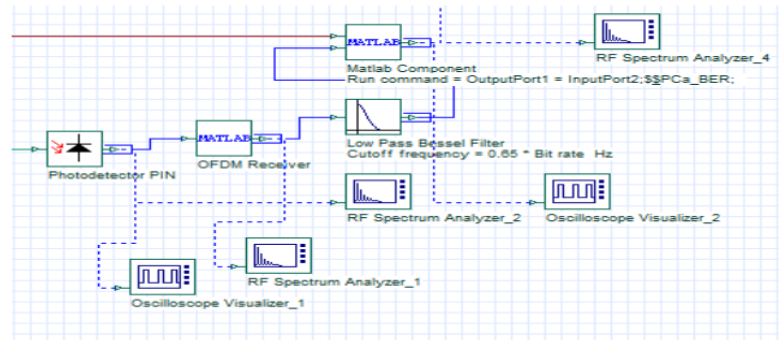

Figure 5. Receiver channel of proposed approach

6.1 Performance evaluation

Delays in the MAC protocol directly impact information transfer within Fi-Wi systems. The effectiveness of the suggested MAC protocol system is initially validated by comparing it with conventional Fi-Wi networks, such as Slotted Aloha, CSMA/CD, and CSMA/CA systems, as well as a wired network incorporating a MAC Protocol. The comparison is based on their Q-factor (Quality Factor) values. Fig. 6 illustrates the Q-factor comparison graph, with time in bit periods on the X-axis and Q-factor values on the Y-axis. Traditional Slotted Aloha, CSMA/CD, and CSMA/CA performances are represented by solid blue, red, and yellow lines, respectively. In contrast, the proposed MAC protocol's performance is depicted by the purple solid line, and the MAC wired protocol's performance is represented by the green solid line. Upon careful examination of the graph, it becomes evident that for Slotted Aloha, the Q-factor reaches a maximum value of approximately 2.4, with a minimum value of 1.3. Similarly, the minimum and maximum Q-factor values for traditional CSMA/CD are around 1.8 and 3.8, respectively. Additionally, the values obtained for the maximum and minimum Q-factor in standard CSMA/CA are the least among all systems, with 1.4 and 0.8, respectively. Conversely, the proposed MAC protocol system outperforms all conventional systems, with a minimum Q-factor of 3.5 and a maximum Q-factor of up to 8.8. When comparing the performance of the proposed Fi-Wi protocol with the wired MAC protocol, initially, the results favor the wired network. However, after a time period of 0.6, the Fi-Wi protocol dominates. These findings affirm that the performance of OFDM systems has significantly improved in terms of Q-factor in MAC protocols. Furthermore, an exhaustive analysis of the suggested MAC protocol's performance is carried out, with a specific focus on eye height. The results obtained are compared with established Fi-Wi methods like slotted Aloha, CSMA/CD, CSMA/CA, and wired MAC protocols. In Figure 7, a generated diagram illustrates the efficiency of the eye pattern, validating the effectiveness

of the proposed Fi-Wi MAC protocol. The diagram's scale is visually depicted across different time frames, with the x-axis representing time and the y-axis denoting amplitude. Upon meticulous examination, it becomes apparent that the eye height amplitude in traditional Fi-Wi networks, such as Slotted Aloha, CSMA/CD, and CSMA/CA, closely aligns with the proposed MAC protocol's eye height diagram. Despite a slight variance in the eye height diagrams of traditional and proposed Fi-Wi networks, the MAC wired protocol stands out with the highest eye height diagram value of 1.1×10^{-3} , in contrast to the nearly 0×10^{-3} values in traditional and proposed Fi-Wi networks. The purple line illustrates the performance of the newly proposed MAC protocols. The graph indicates that the threshold amplitudes in the standard Fi-Wi protocols (Slotted Aloha, CSMA/CD, CSMA/CA) and the proposed MAC protocol closely align, exhibiting minor variations within the range of 0×10^{-6} to 1.4×10^{-6} . In contrast, the threshold value in the wired MAC protocol starts at -1×10^{-6} and progressively decreases to -4.2×10^{-6} by a time period of 0.2. Subsequently, it increases to -1.1×10^{-6} at 0.6 time period before decreasing to approximately -5×10^{-6} at the 1-bit period. Furthermore, after delivering data to the proposed scheme, accompanied by signal modulation, the outcomes are obtained and the entire network's performance is analyzed based on Bit Error Rate (BER).

Fig. 9 presents a comparative chart illustrating the Bit Error Rate (BER) using Gaussian approximation for the proposed MAC Fi-Wi protocol and traditional Fi-Wi protocols including slotted aloha, CSMA/CD, and CSMA/CA, as well as the MAC Wired protocol. Time is represented on the x-axis, and the logarithm of BER is depicted on the y-axis. The solid purple line represents the performance of the proposed MAC protocol, while the solid yellow, red, blue, and green lines correspond to CSMA/CA, CSMA/CD, slotted aloha, and MAC Wired protocol, respectively.

Upon scrutinizing the BER results with Gaussian approximation, it is evident that CSMA/CA achieved the lowest value in the log -2 to log -2.1 range. Subsequently, slotted aloha exhibited the next lowest values, followed by CSMA/CD protocols with ranges spanning from log -1.2 to log -1.23 and log -0.8 to log -0.81, respectively.

Both the proposed MAC protocol and MAC Wired protocol, however, demonstrated higher BER values compared to the other three protocols, with ranges nearing log -0.4 in both instances. This suggests that the proposed MAC protocol displays the least BER, contributing to an overall enhancement in its performance.

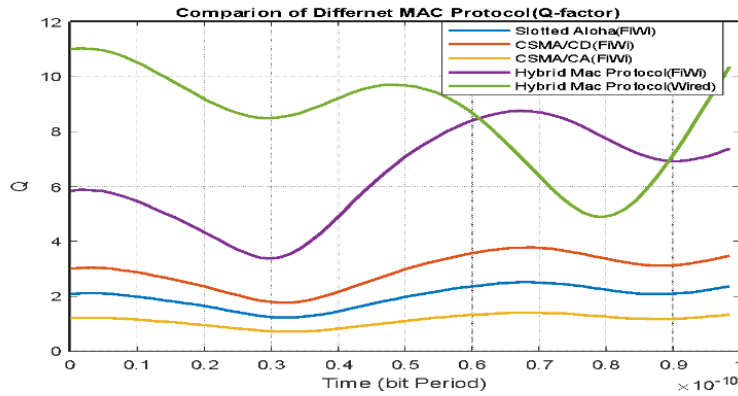

Figure 6. Comparison graph for Q-factor

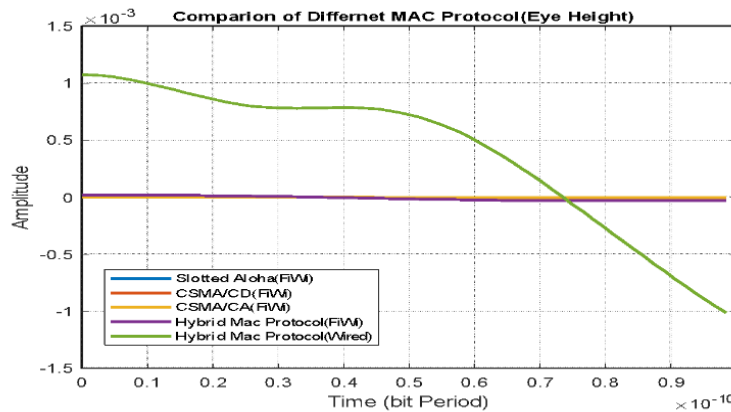

Figure 7. Comparison for Eye pattern Diagrams

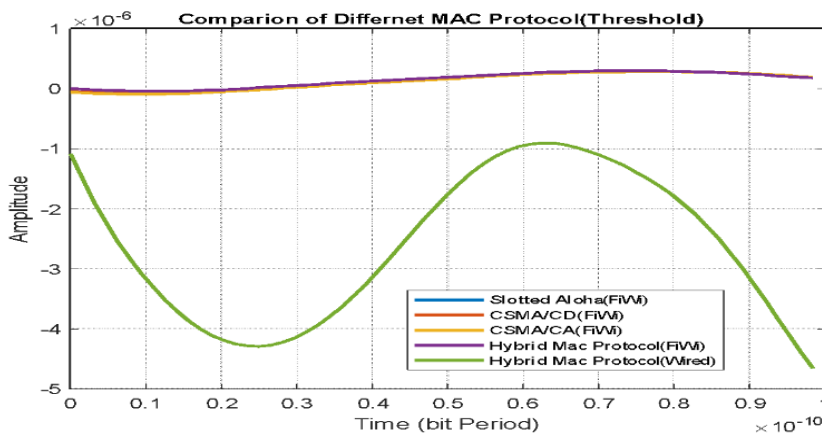

Figure 8. Comparison for threshold amplitude

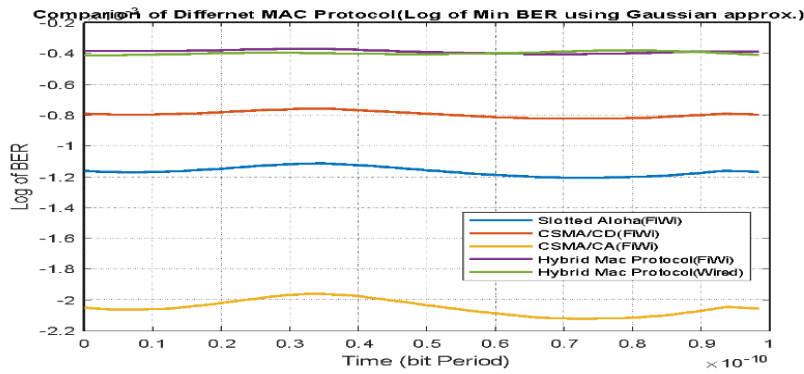

Figure 9. Comparison graph for BER using Gaussian approx

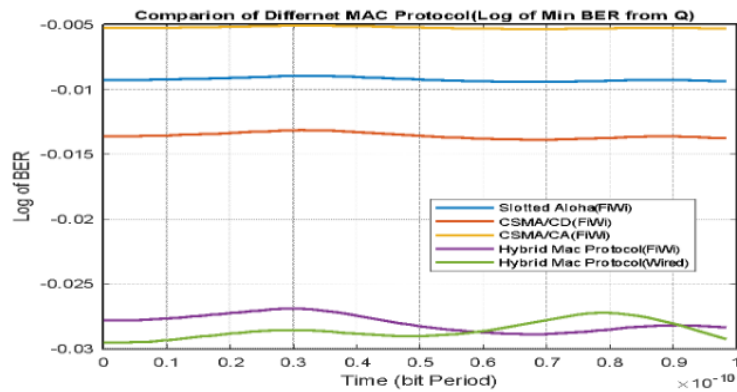

Figure10. Comparison graph for BER from Q Factor

In Figure 10, a graphical representation of the BER during the implementation of the suggested MAC protocols and the comparison protocols (slotted Aloha, CSMA/CD, CSMA/CA, and MAC wired protocols) for

data flow control is depicted. The graph portrays time horizontally and the logarithm of BER vertically. The performance of slotted Aloha is represented by the blue line, CSMA/CD by the red line, CSMA/CA by the yellow

line, MAC Wired protocol by the green line, and the suggested MAC protocol by the solid purple line. Examination of the graph reveals that for CSMA/CA, the BER magnitude is log -0.005, followed by slotted Aloha with a fluctuating BER range around log -0.01, and then CSMA/CD with a BER value exceeding log -0.015. Meanwhile, for the MAC protocol, the BER values range between log -0.033 and -0.037. The logarithm of Min BER from Q-factor fluctuates between -0.03 and -0.025.

Parameters	Values
No. of Nodes	20,40,60
Frame Size	5
Time Scale(msec)	5
CW (Contention window)	[10 100]
Slot Time(msec)	2
SIFS (Short Interframe Space)	6
TIFS (Interframe Space)	2

Protocols	CSMA/CA (%)	CSMA/CD (%)	Slotted Aloha (%)	MAC protocol (%)
Simulation Nodes (Packet transmission efficiency)				
20	90	71	84	93
40	89.13	66.905	80.583	92
60	77.49	61.201	72.562	90.90

The provided table illustrates that, at a simulation node count of 20, Packet transmission efficiencies for CSMA/CA, CSMA/CD, Slotted Aloha, and the proposed MAC protocol were 90%, 71%, 84%, and 93%, respectively. Likewise, at simulation node counts of 40 and 60, the packet transmission efficiencies were 92% and 90%, respectively.

$$S = \frac{1}{M} \sum_{n=0}^N n \left(1 - \frac{1}{M}\right)^{n-1} \binom{N}{n} \rho^n (1 - \rho)^{N-n} \quad \text{--- (1)}$$

Additionally, an assessment of the effectiveness of the suggested MAC protocol has been conducted through a comparative analysis with conventional CSMA/CA, CSMA/CD, and Slotted Aloha protocols. This evaluation involves examining their throughput values across different node variations. Equation 1 is utilized in our proposed work to compute the throughput, allowing for a comprehensive comparison of the protocols' performance.

By employing the provided equation 1, we have calculated the throughput for both the newly proposed MAC protocol and traditional Fi-Wi networks, encompassing CSMA/CD, CSMA/CA, and Slotted Aloha. The outcomes have been systematically recorded in tabular form, as delineated in Table 6.

Table 6: Comparison for Throughput for varying nodes.

Protocols	CSMA/CA (sec)	CSMA/CD (sec)	Slotted Aloha (sec)	MAC protocol (sec)
Simulation Nodes (Delay(sec))				
20	0.5378	0.6195	0.581	0.1180
40	0.5975	0.7040	0.615	0.1425
60	0.712	0.8046	0.672	0.1629

After scrutinizing Table 6, it is evident that the throughput reaches its peak at 99.9% with the proposed MAC protocol when the number of simulating nodes is 20. In contrast, the throughput percentages were 95.4% and 90.6% for 40 and 60 simulating nodes, respectively. Conversely, the throughput values for standard CSMA/CA, CSMA/CD, and Slotted Aloha models were

only 91%, 64%, and 83% when the nodes were 20. Notably, the superiority of the proposed MAC approach is further affirmed by its performance in delay variation, substantiated across varying simulating node scenarios. The computation of delay variation in this study, as expressed in equation 2, contributes to reinforcing the efficacy of the proposed MAC protocol.

$$n_c D = T_s + \sum_{i=1}^{n_c} T_a + \sum_{i=1}^{n_c} T_r + \sum_{i=1}^{n_s} T_{S_i} + \text{Idletime} \quad \text{--- (2)}$$

The evaluation of delay variation in the proposed MAC protocol and comparison with standard CSMA/CA, CSMA/CD, and Slotted Aloha protocols is conducted using a provided equation, involving parameters n_c , n_s , and n_r denoting the total number of retransmissions, collided transmissions, and successful transmissions,

respectively. The variation in delay is delineated in Table 7, indicating a fluctuation from 11.80% to 14.25% to 16.29% as the total number of simulated nodes is adjusted from 20 to 40 to 60, respectively. This observation suggests a proportional increase in delay with the rise in the number of nodes in the proposed model.

Table 7: Comparison for Delay Variation for varying nodes

Protocols	CSMA/CA (%)	CSMA/CD (%)	Slotted Aloha (%)	MAC protocol (%)
Simulation Nodes (Throughput)				
20	91.01	64.66	83.87	99.94
40	86.09	55.489	75.1	95.444
60	87.06	48.553	74.212	90.625

Upon examination of the provided graphs and tables, it is evident that the proposed MAC protocol exhibits superior performance across all parameters, substantiating its dominance.

7. Conclusion

The study presents a novel MAC protocol designed to enhance network efficiency, implemented in MATLAB and validated using Opti-system software. Performance metrics, including Q-factor, BER, threshold, throughput, delay, and packet transmission efficiency, reveal that the proposed MAC protocol outperforms standard protocols (slotted aloha, CSMA/CD, and CSMA/CA) in Q-factor, threshold amplitude, throughput, and packet transmission efficiency. Simulations show the proposed MAC protocol achieving high throughputs of 93%, 92%, and 90%, with packet transmission efficiencies of 99%, 95%, and 90%, and minimal delays of 0.1180sec, 0.1425sec, and 0.1629sec for 20, 40, and 60 simulating nodes. In contrast, CSMA/CA exhibits lower packet transmission efficiency and higher delays. The study also confirms that modifications to CSMACD, CSMACA, and slotted aloha algorithms significantly enhance Fi-Wi network performance, aligning with previous wireless mesh network studies. Overall, the research supports the notion that algorithm adjustments can elevate Fi-Wi network performance.

References

- [1] Ghazisaidi N, Maier M and Assi C M 2009 Fiber-wireless (FiWi) access networks: A survey. *IEEE Communications Magazine*. 47(2): 160-167.
- [2] Kaur P and Saini H S 2020 FSO-Based Analysis of LTE-A MAC Protocols to Achieve Improved QoS. *Journal of Optical Communications*. 41(2).
- [3] Shaddad R Q, Mohammed A A A and Alwajih M K 2021 Survivability of Fiber Wireless (FiWi) Access Network. *International Conference of Technology, Science and Administration (ICTSA)*. 1-5.
- [4] Bhatt U R and Chouhan .N 2013 ONU placement in Fiber-Wireless (FiWi) Networks. *Nirma University International Conference on Engineering (NUI CONE), Ahmedabad, India.* 1-6.
- [5] Zhang H, Hu Y, Wang R, Li Z, Zhang P and Xu R 2021 Energy-Efficient Frame Aggregation Scheme in IoT Over Fiber-Wireless Networks. *IEEE Internet of Things Journal* . 8(13):10779-10791.
- [6] Kramer G , Andrade De. M , Roy R and Chowdhury P 2012 Evolution of optical access networks: Architectures and capacity upgrades. *Proc IEEE*. 100(5):1188-96.
- [7] Demirkol I, Ersoy I C and Alagoz F 2006 MAC protocols for wireless sensor networks: a survey. *IEEE Communications Magazine*.. 44(4) :115-121.
- [8] Narain P, Sharma A, Kumar S and Patle V K 2011 Energy efficient MAC protocols for wireless sensor

networks: A survey. *International Journal of Computer Science & Engineering Survey (IJCES)*.2(.3):121-131.

- [9] Liu X, Ghazisaidi N, Ivanescu L, Kang R and Maier M 2011 On the Tradeoff Between Energy Saving and QoS Support for Video Delivery in IEEE-Based FiWi Networks Using Real-World Traffic Traces. *Journal of Lightwave Technology*. 29(18): 2670-2676.
- [10] Dung V P , Bhaskar R P , and Maier M 2016 Fiber optic vs. wireless sensors in energy-efficient integrated FiWi smart grid networks: An energy-delay and TCO comparison. *35th Annual IEEE International Conference on Computer Communications IEEE Press, San Francisco, CA, USA*.1-9.
- [11] Maier M 2014 Fiber-Wireless (FiWi) Broadband Access Networks in an Age of Convergence: Past, Present and Future. *Advances in Optics*. 23 .
- [12] Funabiki¹ K, Nishio¹ T, Morikura¹ M, Yamamoto¹ K, Murayama² D and Nakahira² K 2017 ATRAS: adaptive MAC protocol for efficient and fair coexistence between radio over fiber-based and CSMA/CA-based WLANs. *Journal Wireless Com Network* . 129.
- [13] Bouazzi I, Zaidi M, Usman Md and Shamim M Z M 2021 A new medium access control mechanism for energy optimization in WSN: traffic control and data priority scheme. *Journal Wireless Com Network* . 12.
- [14] Morimoto Y and Kinoshita K 2021 An Association Control Method in LAA/Wi-Fi Coexistent Networks Considering Uplink/Downlink Communications. 22nd. *Asia-Pacific Network Operations and Management Symposium (APNOMS)*. 382-385.
- [15] Prajapati D 2021 Method for Nearby Product Marketing using Wi-Fi Aware Technology. *International Conference on Intelligent Technologies (CONIT), Hubli, India*.1-5.
- [16] DebBarma D, Zou S, Wang Q, and Lo A 2014 Niemegeers and S. M. H. de Groot Green Fi-Wi LAN . *IEEE 21st Symposium on Communications and Vehicular Technology in the Benelux (SCVT), Delft, Netherlands*. 41-46.



PRABHJOT KAUR pursuing Ph.d in Electronics & Communication Engineering from I.K.G Punjab Technical University Jalandhar, Punjab. She holds Master's in Electronics & Communication Engineering from I.K.G Punjab Technical University, Jalandhar in 2012. Her teaching experience is more than 13 years, presently working as Assistant Professor at BBSBEC, Fatehgarh Sahib, Punjab since 2008. Her area of interest is Wireless and Optical Communication. She presented 16 papers in various national/international conferences and Journals.



Dr. HARDEEP SINGH SAINI obtained his Doctorate degree in Electronics & Communication Engineering in 2012. He holds Master's degree in Electronics & Communication Engineering from Punjab Technical University, Jalandhar passed in 2007. His total experience is 23 years, presently working as a Professor (ECE) and Principal at Indo Global College, Abhipur (New Chandigarh), PUNJAB (INDIA) since June-2007. His area of expertise includes optical communication and wireless communication. He is the author of 6 books in the field of Electronics & Communication Engineering.

He has presented 76 papers in international/national conferences and published 80 papers in international journals (SCI/SCOPUS/IEEE Peer-reviewed Journal). He has also filed/published 04 Patents. He is a fellow and senior member of various prestigious societies like IETE (India), IEEE, IETI China, and SCIEI USA and he is also an editorial member of various international journals and conferences.

PROF. MANOJ KUMAR MISHRA is a well-known academician and researcher. He has 20 years of versatile experience of teaching, research and administration in the capacities of Dean, Director, Registrar, Vice President and Professor. At present he is Professor, Salale University Fitcha, Ethiopia. He is also Secretary of Forum for Interdisciplinary Research Methods, an international association of Research Methods professionals. He has also been awarded honorary D.Sc in Economics and Multidisciplinary Research from Florida, honorary D. Lit from USA and Honorary D. Sc in Management from United Kingdom. He is a Gold Medalist and champion in academic and research world. He specializes in Data Science, Research Methods, Data Analytics, Econometrics and Applied Statistics. He has supervised 12 Ph.D scholars and currently guiding 6 Ph.D scholars. He is the member of executive council, board of studies and academic committees in Indian and foreign universities. He has been honored with more than 20 national and international awards by national and international recognized bodies for immense contribution in teaching, research and administration. He has developed blended video lectures in Advanced Research Methods I and II for master level courses at Ethiopian Civil Service University Addis Ababa, Ethiopia. He has published about 150 research papers and articles in national and international reputed journals. He has 21



patents concerning to data science, data analytics, research methods and econometrics. He has also authored 3 books for PG level on his credit. He has presented more than 200 research papers in national and international seminars and conferences of academicians and researchers.